

# MAJESTIC VERMONT *Castings*

## INSTALLER/CONSUMER SAFETY INFORMATION

PLEASE READ THIS MANUAL  
BEFORE INSTALLING AND  
USING APPLIANCE

### WARNING!

IF THE INFORMATION IN THIS  
MANUAL IS NOT FOLLOWED EX-  
ACTLY, A FIRE OR EXPLOSION MAY  
RESULT CAUSING PROPERTY  
DAMAGE, PERSONAL INJURY OR  
LOSS OF LIFE.

### FOR YOUR SAFETY

Installation and service must  
be performed by a qualified  
installer, service agency or the  
gas supplier.

### WHAT TO DO IF YOU SMELL GAS:

- Do not try to light any appliance.
- Do not touch any electric switch;  
do not use any phone in your  
building.
- Immediately call your gas  
supplier from your neighbor's  
phone. Follow the gas suppliers  
instructions.
- If you cannot reach your gas  
supplier call the fire department.

DO NOT STORE OR USE  
GASOLINE OR OTHER FLAM-  
MABLE VAPORS AND LIQUIDS  
IN THE VICINITY OF THIS OR  
ANY OTHER APPLIANCE.

## Direct Vent

Models: DVRT36  
DVRT39  
DVRT43

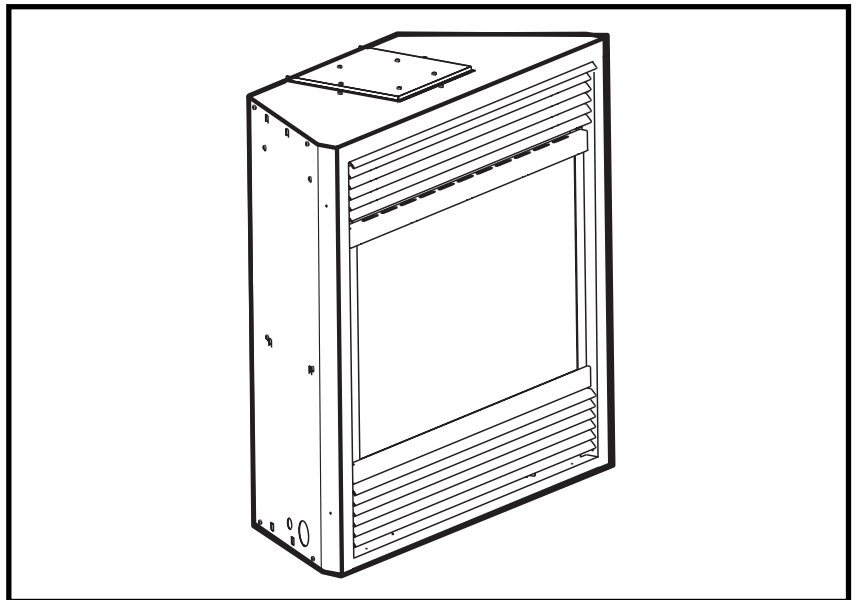

## Homeowner's Installation & Operating Manual



### Vermont Castings, Majestic Products

410 Admiral Blvd. • Mississauga, Ontario, Canada L5T 2N6 • 905-670-7777  
www.majesticproducts.com • www.vermontcastings.com

**INSTALLER: DO NOT DISCARD THIS MANUAL - LEAVE FOR HOMEOWNER**

10002428 11/03 Rev. 5

# Table of Contents

**PLEASE READ THE INSTALLATION & OPERATING INSTRUCTIONS BEFORE USING THE APPLIANCE.**

**Thank You and Congratulations on your purchase of a Vermont Castings, Majestic Products Fireplace.**

**IMPORTANT: Read all instructions and warnings carefully before starting installation. Failure to follow these instructions may result in a possible fire hazard and will void the warranty.**

## Installation & Operating Instructions

General Information .....	3
Locating Your Fireplace .....	3
Fireplace Dimensions .....	4
Clearance to Combustibles .....	6
Mantels .....	6
Hearth .....	6
Framing & Finishing .....	7
Final Finishing .....	7
Gas Specifications .....	7
Gas Inlet and Manifold Pressures.....	7
High Elevations .....	7
Gas Line Installation .....	8
Remote ON/OFF Switch Installation .....	8
Alternate Switch Location .....	8
EB-1 Electrical Box .....	9
Electronic Gas Control Valve.....	9
Optional Top Vent Application .....	10
Installing the DVRT36RMH in a Mobile Home .....	10

## Venting Installation Instructions

General Venting .....	11
General Venting Information -Termination Clearances .....	12
General Information for Connecting Vent Pipes .....	13
Crimped End Pipes .....	13
Twist-lock Pipes .....	14
How to use the Vent Graph .....	14
Rear Wall Vent Application .....	14
Rear Wall Vent Installation .....	15
Vertical Sidewall Application .....	16
Vertical Sidewall Installation .....	17
Below Grade Installation .....	18
Vertical Through-the-Roof Application .....	19
Vertical Through-the-Roof Installation .....	20
Gravity Ducting System .....	21
Clearance to Combustibles .....	21
Venting Components, Twist-lock & Crimp End .....	23

## Operating Instructions

Glass Information .....	25
Louvre Removal .....	25
Window Frame Assembly Removal .....	25
Glass Cleaning .....	25
Installation of Logs & Lava Rock .....	26
Flame & Temperature Adjustment .....	27
Flame Characteristics .....	27
Inspecting the Venting System .....	28
Lighting and Operating Instructions .....	29
Instructions for RF Comfort Control Valve .....	31
Auto Path Chart .....	33
Comfort Valve System Control Sequence of Operation with Transmitter .....	34
Troubleshooting Guide .....	35
Fuel Conversion Instructions .....	38

## Maintenance

Cleaning the Standing Pilot Control System .....	39
--	----

## Replacement Parts

.....	40
-------	----

## Optional Accessories

Fan Kits .....	43
Hard (Direct) Wire Hookup .....	43
Remote Controls .....	44
Ceramic Refractory Panels .....	44
Decorative Bay Window .....	44
Decorative Frame Trim .....	45

## For Use in Mobile Homes: Model DVRT36MH

.....	46
Warranty .....	48
Energide .....	50

# Installation & Operating Instructions

This gas appliance should be installed by a qualified installer in accordance with local building codes and with current CSA-B149.1 Installation codes for Gas Burning Appliances and Equipment. If the unit is being installed in a mobile home, the installation should comply with the current CAN/ CSA Z240.4 code. For U.S.A. Installations follow local codes and/ or the current National Fuel Gas Code, ANSI Z223.1/NFPA 54.

FOR SAFE INSTALLATION AND OPERATION, NOTE THE FOLLOWING:

1. This fireplace gives off high temperatures and should be located out of high traffic areas and away from furniture and draperies.
2. Children and adults should be alerted to the hazards of the high surface temperatures of this fireplace and should stay away to avoid burns or ignition of clothing.
3. Children should be carefully supervised when in the same room as your fireplace.
4. Under no circumstances should this fireplace be modified. Parts removed for servicing should be replaced prior to operating this fireplace again.
5. Installation and any repairs to this fireplace must be performed by a qualified installer, service agency or gas supplier. A professional service person should be contacted to inspect this fireplace annually. Make it a practice to have all of your gas fireplaces checked annually. More frequent cleaning may be required due to excess lint and dust from carpeting, bedding material, etc.
6. Control compartments, burners and air passages in this fireplace should be kept clean and free of dust and lint. Make sure the gas valve and pilot light are turned off before you attempt to clean this fireplace.
7. The venting system (chimney) of this fireplace should be checked at least once a year and if needed your venting system should be cleaned.
8. Keep the area around your fireplace clear of combustible materials, gasoline and other flammable vapor and liquids. This fireplace should not be used as a drying rack for clothing, nor should Christmas stockings or decorations be hung in the area of it.
9. Under no circumstances should any solid fuels (wood, coal, paper or cardboard etc.) be used in this fireplace.
10. The flow of combustion and ventilation air must not be obstructed in any way.
11. When fireplace is installed directly on carpeting, vinyl tile or any combustible material other than wood, this fireplace must be installed on a metal or wood panel extending the full width and depth of the fireplace.
12. This fireplace requires adequate ventilation and combustion air to operate properly.
13. This fireplace must not be connected to a chimney flue serving a separate solid fuel burning fireplace.
14. When the fireplace is not in use it is recommended that the gas valve be left in the "OFF" position.

**Proposition 65 Warning:** Fuels used in gas, wood-burning or oil fired appliances, and the products of combustion of such fuels, contain chemicals known to the State of California to cause cancer, birth defects and other reproductive harm.

California Health & Safety Code Sec. 25249.6

**This appliance may be installed in an aftermarket permanently located, manufactured home or mobile home, where not prohibited by local codes.**

**This appliance is only for use with the type of gas indicated on the rating plate. This appliance is not convertible for use with other gases, unless a certified kit is used.**

**The DVRT36RMH has been approved for mobile home installations.**

## IMPORTANT:

### PLEASE REVIEW THE FOLLOWING CAREFULLY

Remove any plastic from trim parts before turning the fireplace "ON".

It is normal for fireplaces fabricated of steel to give off some expansion and/or contraction noises during the start up or cool down cycle. Similar noises are found with your furnace heat exchanger or car engine.

It is not unusual for your Vermont Castings, Majestic Products gas fireplace to give off some odor the first time it is burned. This is due to the curing of the paint and any undetected oil from the manufacturing process.

**Please ensure that your room is well ventilated - open all windows.**

It is recommended that you burn your fireplace for at least ten (10) hours the first time you use it. If the optional fan kit has been installed, place the fan switch in the "OFF" position during this time.

## Locating the Fireplace

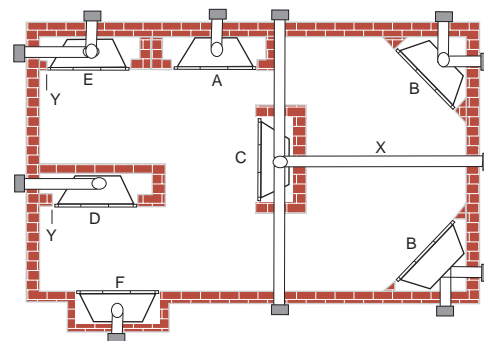

LU584-1

**Fig. 1** Locating the Gas Fireplace.

- |                     |                         |                       |
|---------------------|-------------------------|-----------------------|
| A) Flat on wall     | B) Cross corner         | C) Island**           |
| D) Room divider*/** | E) Flat on wall corner* | F) Chase installation |
|                     |                         | Y) 6 in. minimum      |

### Notes (Fig. 1):

\* When you install your Vermont Castings, Majestic Products fireplace in (D) Room divider or (E) Flat on wall corner positions, a minimum of (Y), 6 in. (153 mm) clearance must be maintained from the perpendicular wall and the front of the fireplace.

\*\*Island (C) and Room Divider (D) installation is possible if the horizontal portion of the vent system (X) does not exceed 20 ft. (610 cm). See details in Venting Section.

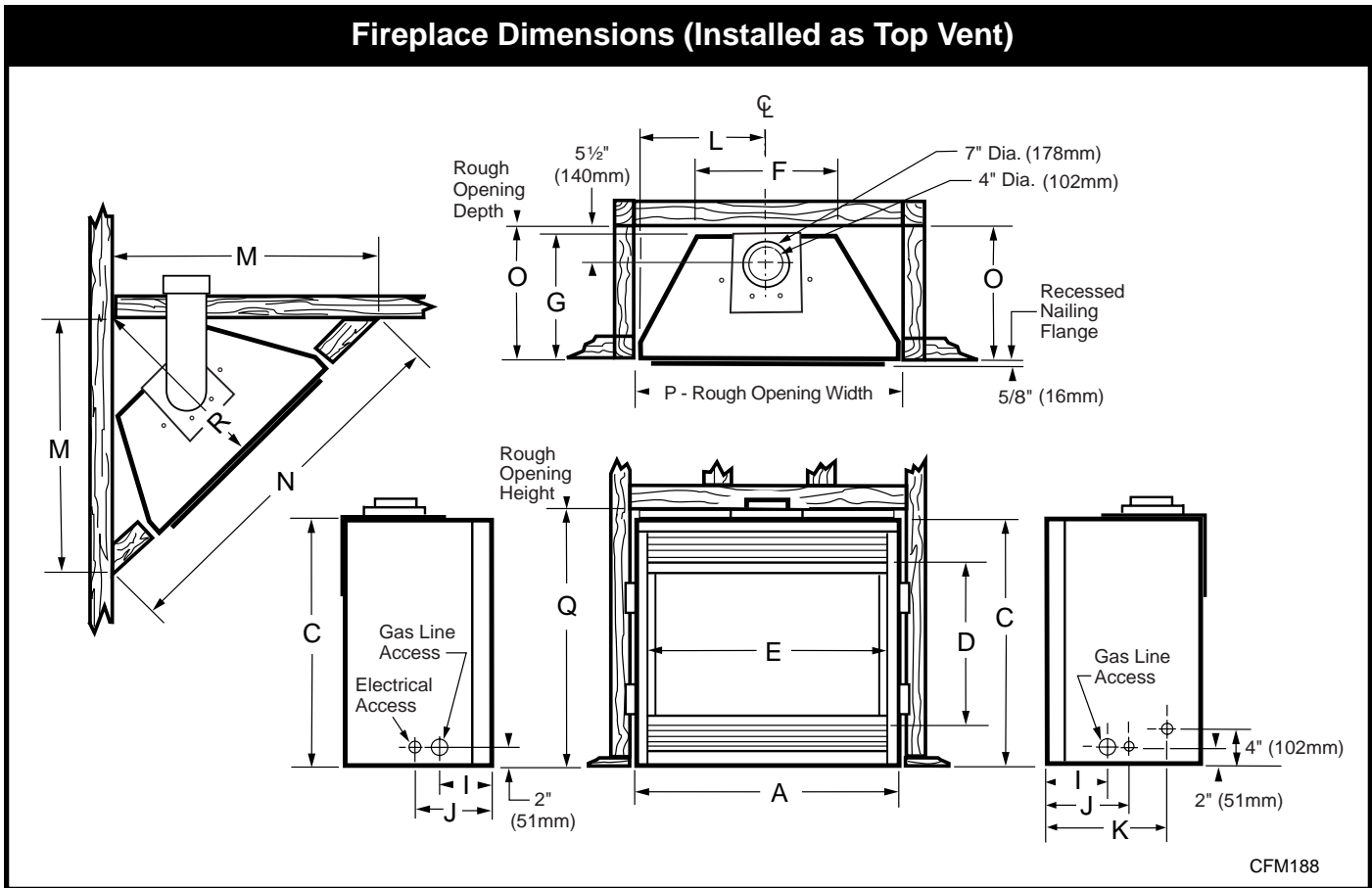

Fig. 2 Fireplace specifications and framing dimensions.

Ref.	DVRT36	DVRT39	DVRT43
A	36" (914mm)	39" (991mm)	43" (1092mm)
B	37¼" (946mm)	37¼" (946mm)	40" (1016mm)
C	34¼" (870mm)	34¼" (870mm)	37" (940mm)
D	21" (533mm)	21" (533mm)	23½" (597mm)
E	32⅞" (835mm)	35⅞" (911mm)	39⅞" (1012mm)
F	20" (508mm)	24⅜" (619mm)	31" (787mm)
G	14¼" (362mm)	15¾" (400mm)	16¼" (412mm)
H	6" (152mm)	6" (152mm)	6" (152mm)
I	5½" (140mm)	5½" (140mm)	5½" (140mm)
J	7¾" (197mm)	8½" (216mm)	8½" (216mm)
K	10¾" (273mm)	12½" (318mm)	12½" (318mm)
L	18" (457mm)	19½" (495mm)	21½" (546mm)
<b>Framing Dimensions</b>			
M	36" (914mm)	40" (1016mm)	44" (1118mm)
N	51" (1295mm)	56" (1422mm)	62¼" (1581mm)
O	14½" (368mm)	16½" (419mm)	16½" (419mm)
P	36½" (927mm)	39½" (1003mm)	43½" (1105mm)
Q	35" (889mm)	35" (889mm)	37¾" (959mm)
R	25½" (648mm)	28" (711mm)	36⅞" (918mm)

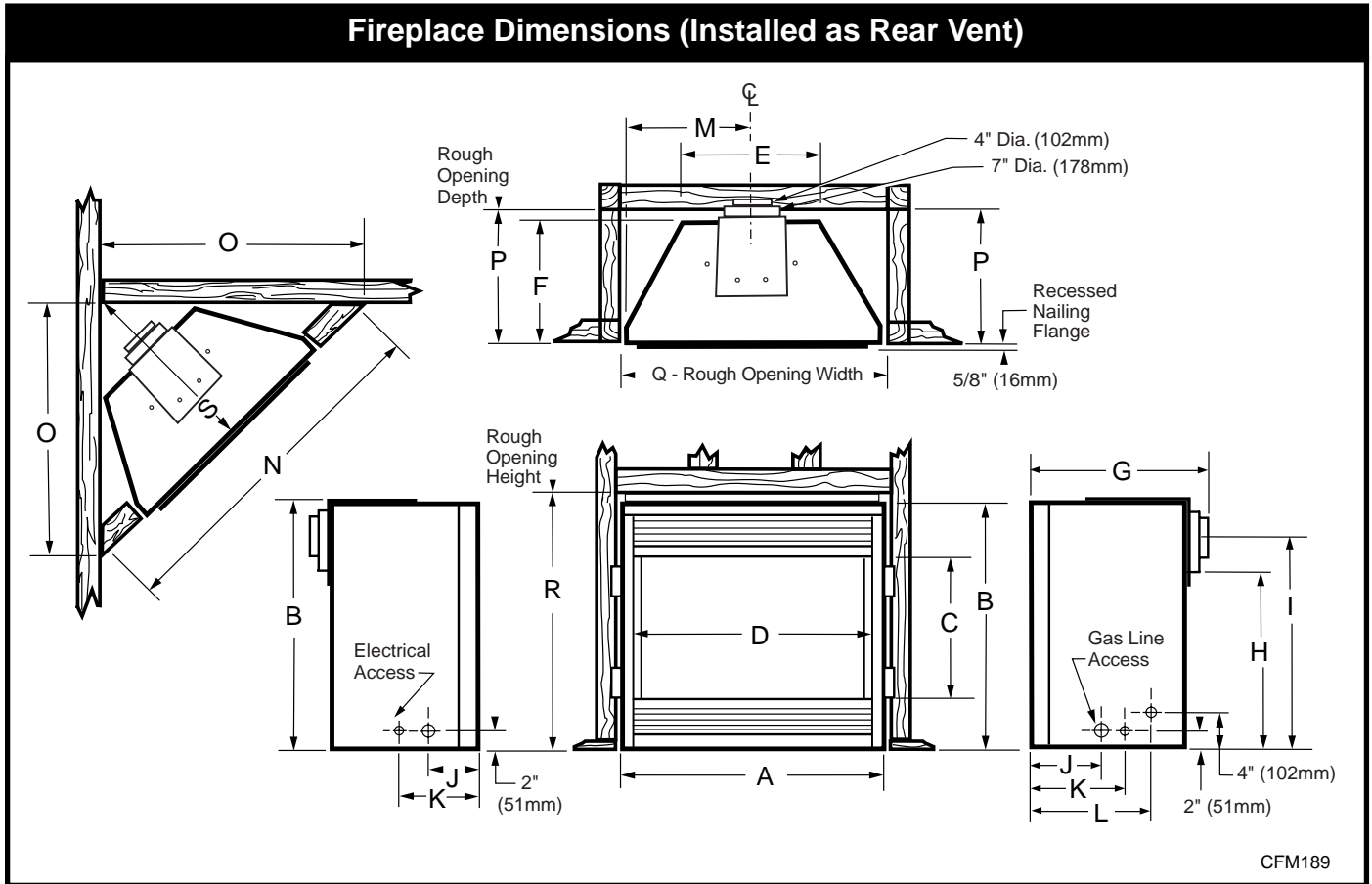

Fig. 3 Fireplace specifications and framing dimensions.

Ref.	DVRT36	DVRT39	DVRT43
A	36" (914mm)	39" (991mm)	43" (1092mm)
B	34 1/4" (870mm)	34 1/4" (870mm)	37" (940mm)
C	21" (533mm)	21" (533mm)	23 1/2" (597mm)
D	32 7/8" (835mm)	35 7/8" (911mm)	39 7/8" (1012mm)
E	20" (508mm)	24 3/8" (610mm)	31" (787mm)
F	14 1/4" (362mm)	15 3/4" (400mm)	16" (406mm)
G	16 3/4" (425mm)	18" (457mm)	18 1/4" (464mm)
H	25 1/4" (641mm)	25 1/4" (641mm)	28" (711mm)
I	28 3/4" (730mm)	28 3/4" (730mm)	31 1/2" (800mm)
J	5 1/2" (140mm)	5 1/2" (140mm)	5 1/2" (140mm)
K	7 3/4" (197mm)	8 1/2" (216mm)	8 1/2" (216mm)
L	10 3/4" (273mm)	12 1/2" (318mm)	12 1/2" (318mm)
M	18" (457mm)	19 1/2" (495mm)	21 1/2" (546mm)
<b>Framing Dimensions</b>			
N	59 9/16" (1436mm)	62 1/4" (1581mm)	68 1/2" (1740mm)
O	40" (1016mm)	44" (1118mm)	48" (1219mm)
P	14 1/2" (368mm)	16 1/2" (419mm)	16 1/2" (419mm)
Q	36 1/2" (927mm)	39 1/2" (1003mm)	43 1/2" (1105mm)
R	35" (889mm)	35" (889mm)	37 3/4" (959mm)
S	25 1/2" (648mm)	28" (711mm)	36 1/8" (918mm)

**Clearance to Combustibles**

Appliance

Top .....	0" (0mm)
Bottom .....	0" (0mm)
Side .....	0" (0mm)
Back .....	0" (0mm)

Venting

Concentric sections of DV Vent .....	1" (25mm)
Non-concentric sections of DV Vent	
Sides and bottom .....	1" (25mm)
Top .....	2" (51mm)

**Mantels**

The height a combustible mantel is fitted above the fireplace is dependent on the depth of the mantel. This also applies to the distance between the mantel leg (if fitted) and the fireplace.

Refer to Figures 4a and 4b and the Mantel Charts below them for correct mounting heights and widths.

- The distances and reference points are not affected by the fitting of a bay window front trim kit.
- Noncombustible mantels and legs may be installed at any height and width around the appliance.
- When using paint or lacquer to finish the mantel, it must be heat-resistant to prevent discoloration.

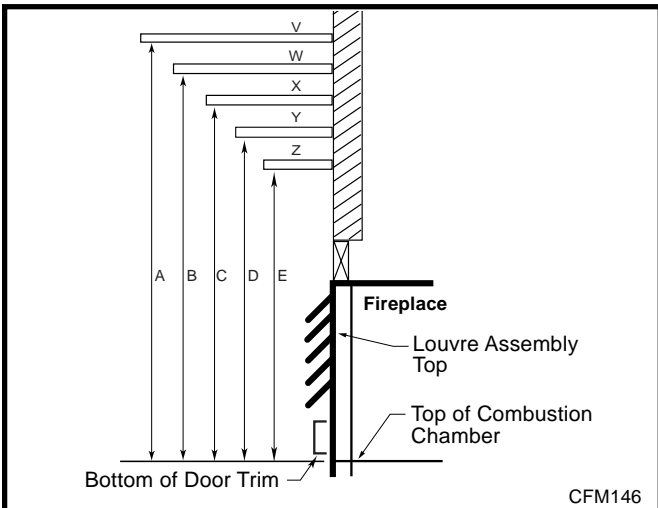

**Mantel Chart**

Ref.	Mantel Shelf or Breast Plate Depth	Ref.	Mantel from Top of Comb. Chamber
V	10" (254mm)	A	19" (483mm)
W	8" (203mm)	B	17" (432mm)
X	6" (152mm)	C	15" (381mm)
Y	4" (101mm)	D	13" (330mm)
Z	2" (51mm)	E	11" (279mm)

**Fig. 4a** Combustible mantel leg minimum installation.

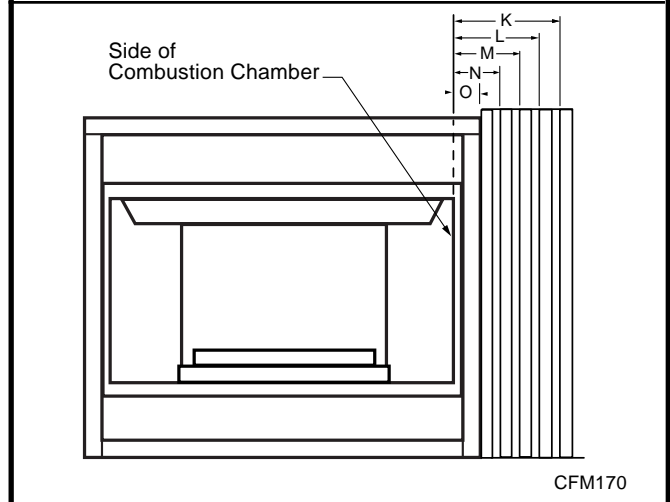
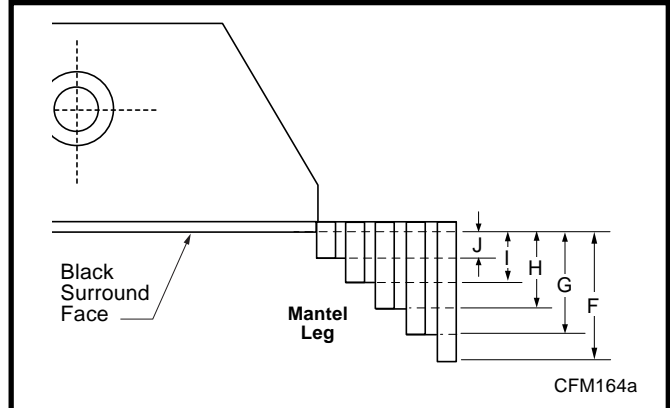

Ref.	Mantel Leg Depth	Ref.	Mantel Leg from Side of Comb. Opening
F	10" (254mm)	K	11½" (292mm)
G	8" (203mm)	L	9½" (241mm)
H	6" (152mm)	M	7½" (191mm)
I	4" (101mm)	N	5½" (140mm)
J	2" (51mm)	O	3½" (89mm)

**Fig. 4b** Combustible mantel leg minimum installation.

**Hearth**

Although a hearth is not mandatory, one is recommended for aesthetic purposes. A noncombustible hearth which projects out 12" (305mm) or more from the front of the fireplace is recommended.

**Cold Climate Installation Recommendation:**



**When installing this unit against a noninsulated exterior wall or chase, it is mandatory that the outer walls be insulated to conform to applicable insulation codes.**

## Framing & Finishing



**Check the fireplace to make sure it is leveled and properly positioned.**

1. Choose the unit location.
2. Place the unit into position and secure it to the floor with 1½" (38mm) screws or nails. Holes for securing the unit to floor are located behind the access door grille on the left and right sides of the unit.
3. Frame in the fireplace with a header across the top. It is important to allow for the finished wall face when setting the depth of the frame.
4. Attach the fireplace to the frame using the adjustable frame drywall strips (located behind the access door for shipping). Preset the depth to suit the facing material of the wall. The strips are adjustable to 1/2" (13mm), 5/8" (16mm) or 3/4" (19mm). (Fig. 5)
5. Screw through the slotted holes in the drywall strip and into predrilled holes in fireplace side. Measure from face of fireplace to the face of the drywall strip to confirm the final depth.

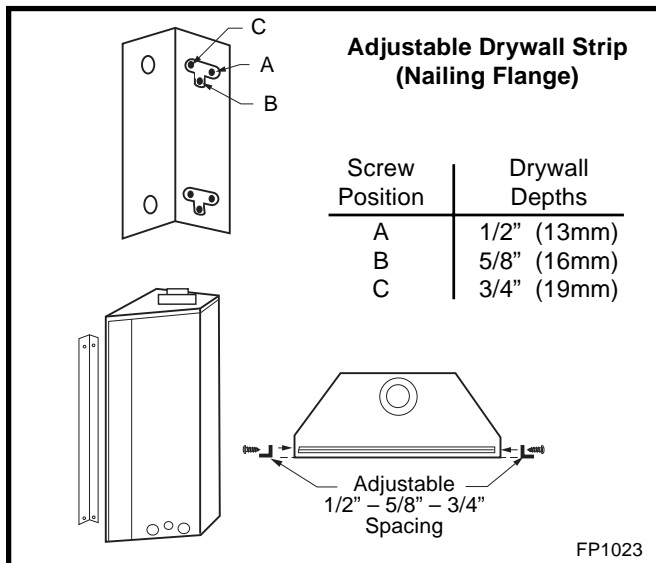

Fig. 5 Adjustable drywall strip (nailing flanges).

## Final Finishing

Noncombustible materials such as brick or tile may be extended over the edges of the face of the appliance. **DO NOT cover the window frame assembly, any vent, louvre assembly top or louvre assembly bottom.**

If a Trim Kit is to be installed on the fireplace, the brick or tile will have to be installed flush with the edges of the appliance.

## Gas Specifications

Model	Fuel	Gas Control	Max. Input BTU/h	Min. Input BTU/h
DVRT36RN	Nat	Millivolt	25,000	17,500
DVRT36RP	Prop	Millivolt	25,000	18,750
DVRT36EN	Nat	24V Hi/Lo	25,000	17,500
DVRT36EP	Prop	24V Hi/Lo	25,000	18,750
DVRT36RFN	Nat	Comfort Control	25,000	17,500
DVRT36RFP	Prop	Comfort Control	25,000	18,750
DVRT36RMH	Nat/Prop	Millivolt	25,000	17,500
DVRT39RN	Nat	Millivolt	30,000	21,000
DVRT39RP	Prop	Millivolt	30,000	22,500
DVRT39EN	Nat	24V Hi/Lo	30,000	21,000
DVRT39EP	Prop	24V Hi/Lo	30,000	22,500
DVRT43RN	Nat	Millivolt	33,000	23,100
DVRT43RP	Prop	Millivolt	33,000	24,750
DVRT43EN	Nat	24V Hi/Lo	33,000	23,100
DVRT43EP	Prop	24V Hi/Lo	33,000	24,750

## Gas Inlet and Manifold Pressures

	Natural	LP (Propane)
Inlet Minimum	5.5" w.c.	11.0" w.c.
Inlet Maximum	14.0" w.c.	14.0" w.c.
Manifold Pressure	3.5" w.c.	10.0" w.c.

## DVRT36/ DVRT36RMH/ DVRT39/ DVRT43 Certified To

**ANSI Z21.88-2002/ CSA 2.33-2002  
Vented Gas Fireplace Heaters**

## High Elevations

Input ratings are shown in BTU per hour (BTU/h) and are certified without deration for elevations up to 4,500 feet (1,370 m) above sea level.

For elevations above 4,500 feet (1,370 m) in USA, installations must be in accordance with the current ANSI Z223.1/NFPA 54 and/or local codes having jurisdiction.

In Canada, please consult provincial and/or local authorities having jurisdiction for installations at elevations above 4,500 feet (1,370 m).

## Gas Line Installation



**When purging the gas lines, the front glass must be removed.**

The gas pipeline can be brought in through the side of the fireplace as well as the bottom. Knockouts are provided on the bottom behind the valve to allow for the gas pipe installation and testing of any gas connection. It is most convenient to bring the gas line in from the rear right side of the valve as this allows fan installation or removal without disconnecting the gas line.

The gas line connection can be made with properly tinned 3/8" copper tubing, 3/8" rigid pipe or an approved flex connector. Since some municipalities have additional local codes, it is always best to consult your local authority and the **CSA-B149.1** installation codes.

For USA installations consult the current National Fuel Gas Code, **ANSI Z223.1/NFPA 54**.

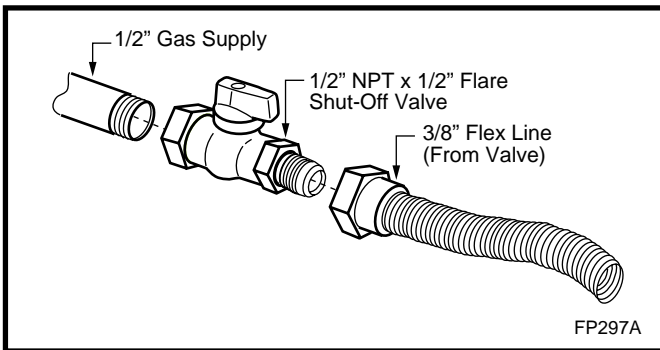

Fig. 6 Typical gas supply installation.



**Always check for gas leaks with a mild soap and water solution applied with a brush no larger than 1" (25 mm). Never apply soap and water solution with a spray bottle. Do not use an open flame for leak testing.**



**The fireplace valve must not be subjected to any test pressures exceeding 1/2 p.s.i. Isolate or disconnect this or any other gas appliance control from the gas line when pressure testing.**

The gas control is equipped with a captured screw type pressure test point; therefore, it is not necessary to provide a 1/8" test point upstream of the control.

When using copper or flex connector use only approved fittings. Always provide a union when using black iron pipe so that the gas line can be easily disconnected for burner or fan servicing. (Fig. 6) See the gas specifications for pressure details and ratings.

## Remote ON/OFF Switch Installation



**Do not wire the remote ON/OFF wall switch for this gas appliance into a 120 V power supply.**

1. Thread the wiring through the electrical knockout located on either side of the unit. Take care not to cut the wire or insulation on metal edges. Ensure the wire is secured and protected from possible damage. Run one end to the gas control valve and the other end to the conveniently located wall switch.
2. Attach the wire to the **ON/OFF** switch and install the switch into the receptacle box. Attach the cover plate to the switch.
3. Connect the wire to the gas control valve. (Fig. 7)

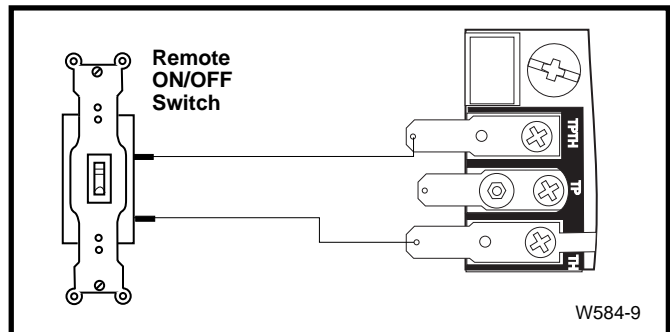

Fig. 7 Remote switch wiring diagram for R models.

## Alternate Switch Location

The remote switch can be installed on either side of the access door. Mount the switch to the bracket provided and screw the bracket to either side of the frame, using the pre-punched holes. (Fig. 8)

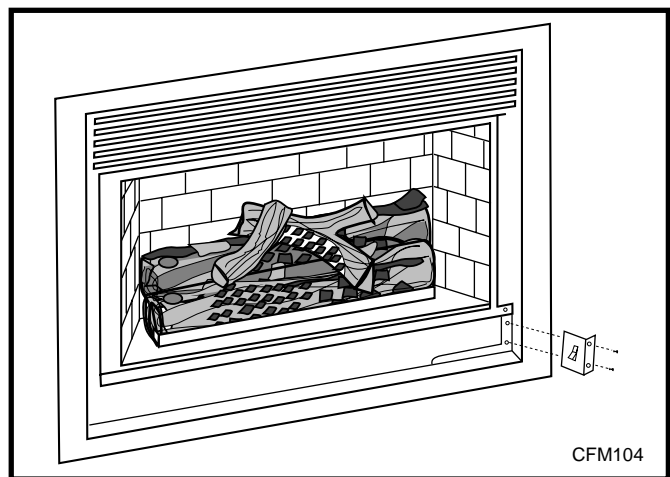

Fig. 8 Alternate switch location.



## EB-1 Electrical Box



The fireplace, when installed, must be electrically connected and grounded in accordance with local codes; or, in the absence of local codes, with the current CSA C22.1 Canadian Electrical Code



For USA installations, follow the local codes and the national electrical code ANSI/NFPA No. 70.



It is strongly suggested that a licensed electrician perform the wiring of the EB-1 Electrical Junction Box.



Ensure that the power to the supply line has been disconnected before commencing this procedure.

The EB-1 Electrical junction box is fitted with this model to provide for easy installation of an optional fan kit.

To connect the EB-1 box to the house electrical supply follow the steps below:

1. Unscrew the retaining screw from the EB-1 base plate (Fig. 9), and remove the EB-1 assembly from the fireplace.
2. Remove the front cover of the EB-1 box.
3. Remove the plug socket assembly from the EB-1 box.
4. Feed the supply line in from the outside through the cable clamp. (Fig. 9)
5. Connect black wire of the power supply line to the brass screw (polarized) of the socket assembly.
6. Connect the white wire of the power line to the chrome screw of the socket assembly.
7. Connect the ground wire of the supply line to the green screw of the socket assembly.
8. Refit the socket assembly back into the electrical box and replace the cover plate. Secure the cable with the clamp on the outside of the unit to prevent strain on the connections.

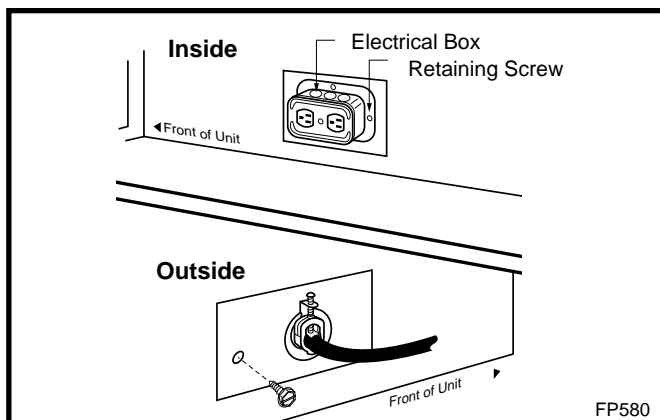

Fig. 9 EB-1 receptacle.

## Electronic Gas Control Valve

This appliance may be fitted with a Honeywell ignition module.

Installation of the remote on/off starter switch on electronic ignition units:

1. Thread the wiring through the holes on the side panels of the appliance. Take care not to cut the wire or insulation on metal edges. Route the wire to a conveniently located receptacle box.
2. Attach the wire to the **ON/OFF** switch and install the switch into the receptacle box. (Fig. 10)
3. Connect the White wire from the wall switch to the Black wire from the transformer, using an approved wire nut. Connect the Black wire from the wall switch to the Black wire running from the #6 position of the ignition module, also using an approved wire nut.

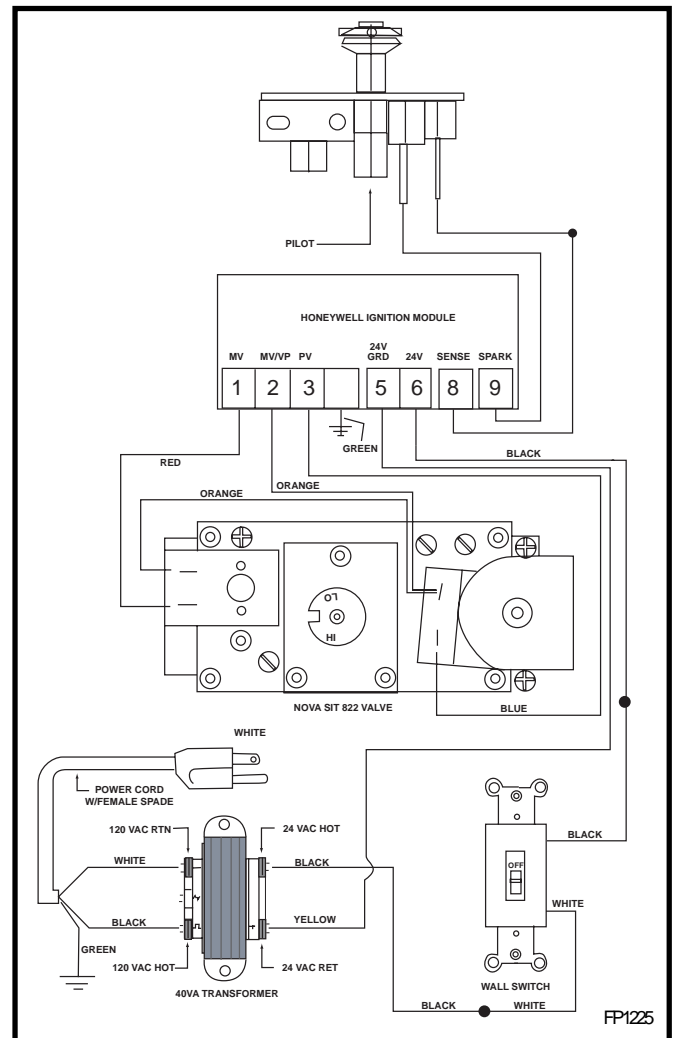

Fig. 10 Honeywell ignition module.

## Optional Top Vent Application

The DVRT appliance is shipped as a rear vent unit. If the installation layout requires the unit to be a top vent configuration the appliance can be converted by following the steps below.



**When removing and refitting the plates and adapter, be sure the associated gaskets are undamaged and refitted as required.**

1. Remove the ten (10) screws securing the outer collar adapter to the fireplace body. (Fig. 11)
2. Set the collar aside, complete with the gasket. **Do not damage the gasket, as the adapter and gasket must be refitted.**
3. Remove the insulation material (exposed in Step 2) from the top of the unit. (Fig. 12) This material can be discarded. However, if the unit is converted back to rear vent for any reason a new piece of insulation material approved by Vermont Castings, Majestic Products must be used for this purpose.
4. Remove the four (4) screws securing the flue cover plate to the top of the intake box and remove the cover and gasket. (Fig. 12)
5. Remove the four (4) screws securing the flue pipe to the back of the intake box and remove the pipe and gasket. (Fig. 12)
6. Secure the plate and gasket removed in Step 4 over the flue opening in the back of the intake box. Ensure the gasket is in place and undamaged.
7. Install the flue pipe and gasket removed in Step 5 over the flue opening in the top of the intake box. (Fig. 13)
8. Refit the outer collar adapter and gasket to the unit with the round collar on the top. Secure the adapter with the ten (10) screws removed in Step 1.



**When converting appliance to top vent, ensure the insulation material referred to in Step 3 is completely removed.**

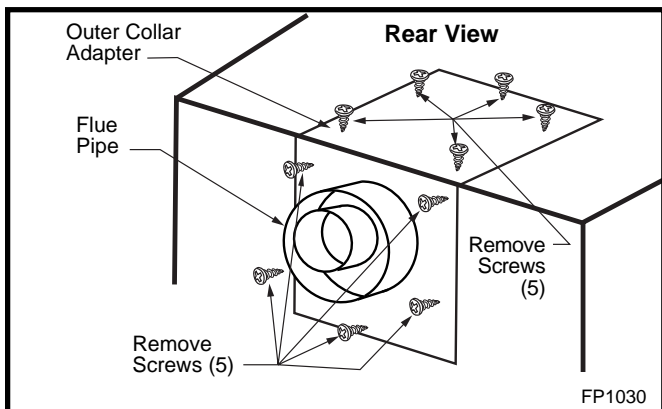

Fig. 11 Remove screws from outer collar adapter.

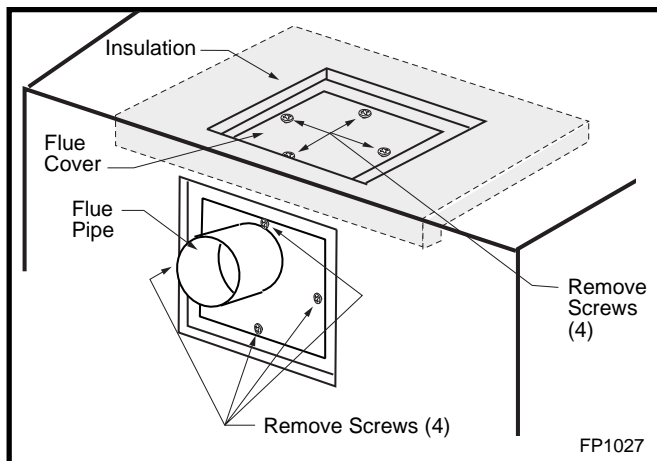

Fig. 12 Remove flue cover, flue pipe and insulation pad.



**The insulation pad extends beyond the opening in the top of the unit. Be sure to remove all of the insulation material before completing the conversion.**

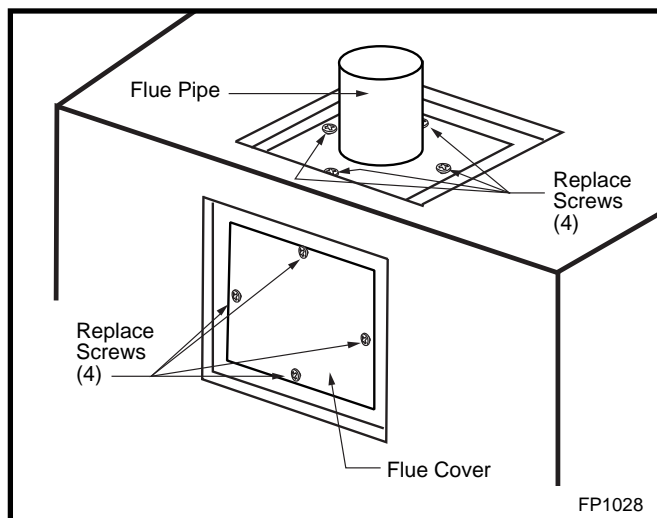

Fig. 13 Flue cover and flue pipe location.



**After conversion to top vent configuration, the 4" (102mm) flue pipe should be concentric within the 7" (175mm) outer collar.**

## Installing the DVRT36RMH in a Mobile Home

**NOTE: Refer to "For Use in Mobile Homes: Model DVRT36RMH" on Pages 46 and 47.**

## General Venting

Your fireplace is approved to be vented either through the side wall, or vertically through the roof.

**NOTE: Only venting components specifically approved and labeled for this fireplace may be used.**

- Venting terminals shall not be recessed into a wall or siding.
- Horizontal venting must be installed on a level plane without any incline or decline.
- There must not be any obstructions such as bushes, garden sheds, fences, decks, or utility buildings within 24" (610mm) from the front of the termination hood.

- Do not locate the termination hood where excessive snow or ice buildup may occur.
- Be sure to check and clear the vent termination area after snow falls, to prevent accidental blockage of venting system.
- When using snow blowers, make sure snow is not directed toward the vent termination area.

### Location of Vent Termination



**It is imperative to observe minimum clearances (shown on the following page) when locating vent terminations.**

**General Venting Information - Termination Location**

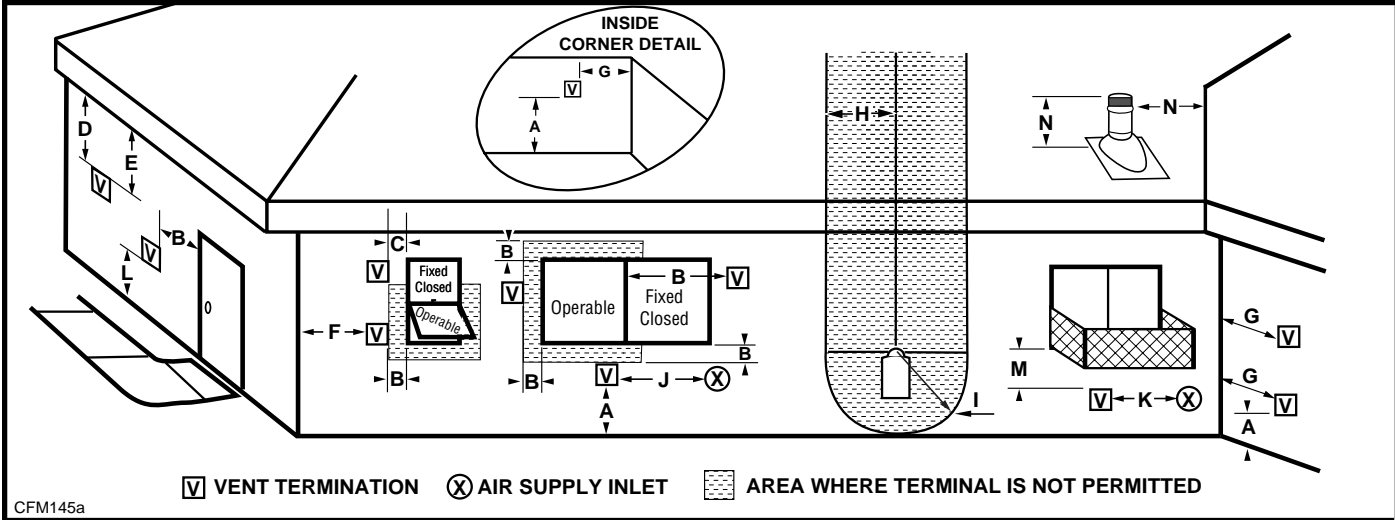

	Canadian Installations <sup>1</sup>	US Installations <sup>2</sup>
A = Clearance above grade, veranda, porch, deck, or balcony	12" (30cm)	12" (30cm)
B = Clearance to window or door that may be opened	6" (15cm) for appliances < 10,000Btuh (3kW), 12" (30cm) for appliances > 10,000 Btuh (3kW) and < 100,000 Btuh (30kW), 36" (91cm) for appliances > 100,000 Btuh (30kW)	6" (15cm) for appliances < 10,000 Btuh (3kW), 9" (23cm) for appliances > 10,000 Btuh (3kW) and < 50,000 Btuh (15kW), 12" (30cm) for appliances > 50,000 Btuh (15kW)
C = Clearance to permanently closed window	12" (305mm) recommended to prevent window condensation	12" (305mm) recommended to prevent window condensation
D = Vertical clearance to ventilated soffit located above the terminal within a horizontal distance of 2 feet (610mm) from the center line of the terminal	18" (458mm)	18" (458mm)
E = Clearance to unventilated soffit	12" (305mm)	12" (305mm)
F = Clearance to outside corner	see next page	see next page
G = Clearance to inside corner (see next page)	see next page	see next page
H = Clearance to each inside of center line extended above meter/regulator assembly	3' (91 cm) within a height of 15' above the meter/regulator assembly	3' (91cm) within a height of 15' above the meter/regulator assy
I = Clearance to service regulator vent outlet	3' (91cm)	3' (91cm)
J = Clearance to nonmechanical air supply inlet to building or the combustion air inlet to any other appliances	6" (15cm) for appliances < 10,000 Btuh (3kW), 12" (30cm) for appliances > 10,000 Btuh (3kW) and < 100,000 Btuh (30kW), 36" (91cm) for appliances > 100,000 Btuh (30kW)	6" (15cm) for appliances < 10,000 Btuh (3kW), 9" (23cm) for appliances > 10,000 Btuh (3kW) and < 50,000 Btuh (15kW), 12" (30cm) for appliances > 50,000 Btuh (15kW)
K = Clearance to a mechanical air supply inlet	6' (1.83m)	3' (91cm) above if within 10' (3m) horizontally
L = Clearance above paved sidewalk or paved driveway located on public property	7' (2.13m)†	7' (2.13m)†
M = Clearance under veranda, porch, deck or balcony	12" (30cm)‡	12" (30cm)‡
N = Clearance above a roof shall extend a minimum of 24" (610mm) above the highest point when it passes through the roof surface, and any other obstruction within a horizontal distance of 18" (450mm).		

1 In accordance with the current CSA-B149 Installation Codes  
 2 In accordance with the current ANSI Z223.1/NFPA 54 National Fuel Gas Codes  
 † A vent shall not terminate directly above a sidewalk or paved driveway which is located between two single family dwellings and serves both dwellings  
 ‡ only permitted if veranda, porch, deck or balcony is fully open on a minimum 2 sides beneath the floor:  
 NOTE: 1. Local codes or regulations may require different clearances.  
 2. The special venting system used on Vermont Castings, Majestic Products Direct Vent Fireplaces are certified as part of the appliance, with clearances tested and approved by the listing agency.

**Fig. 14** Vent termination clearances.

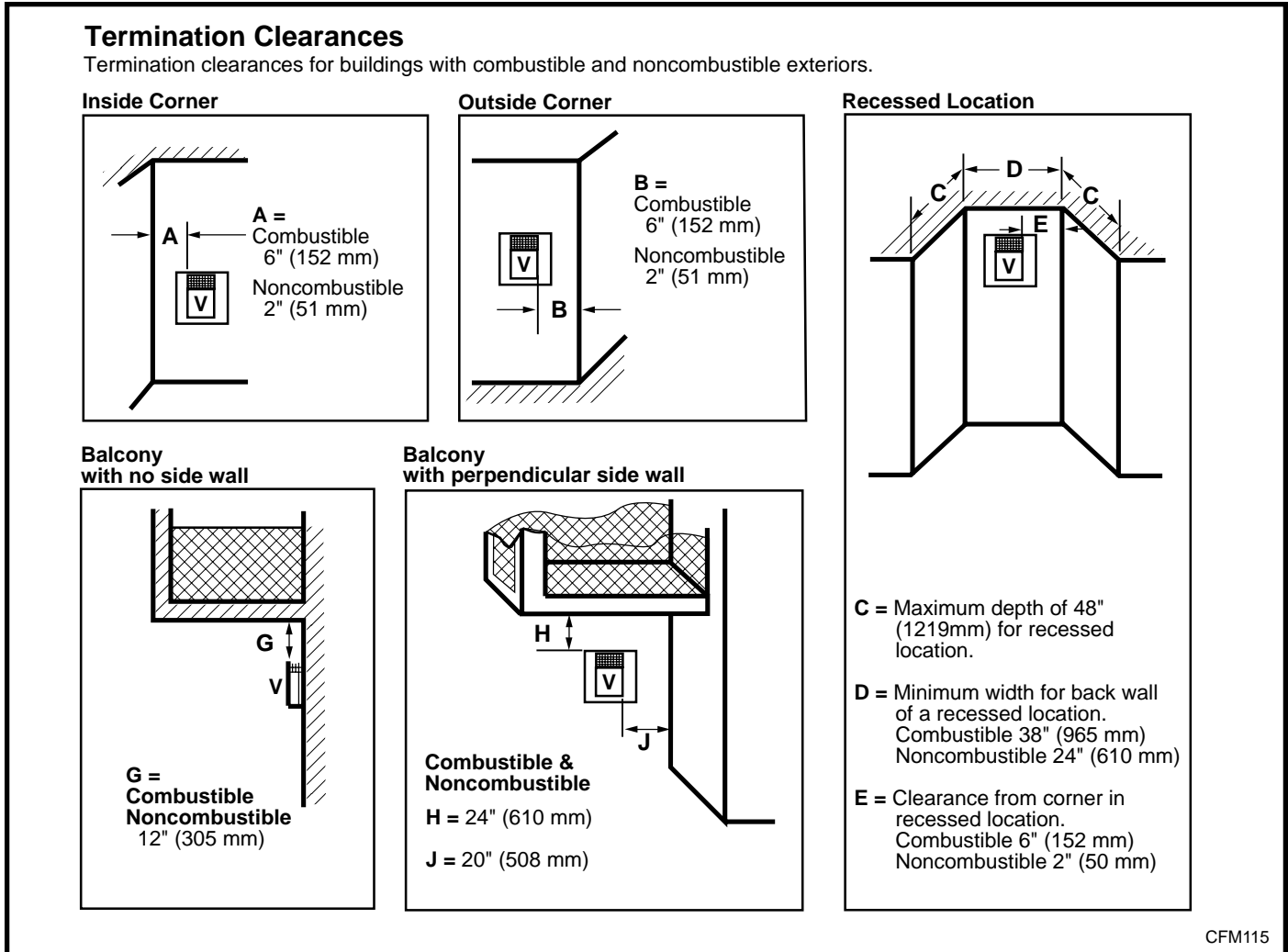

Fig. 15 Termination clearances.

## General Information for Connecting Vent Pipes

### Crimped End Pipes

Before joining elbows and pipes, apply a bead of high temperature sealant to the crimped end of the elbow or pipe.

Join the pipes using a 2" (51mm) overlap and secure the joints with three (3) sheet metal screws. (Fig. 16) Wipe off excess sealant.

#### Canadian Installations:

The venting system must be installed in accordance with the current CSA-B149.1 installation code.

#### USA Installations:

The venting system must conform to local codes and/or the current National Fuel Code ANSI Z223.1/NFPA 54.

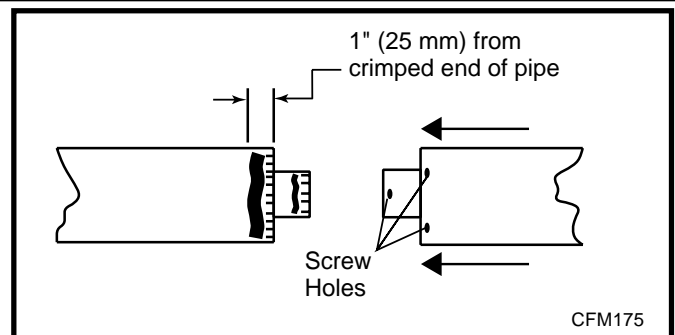

Fig. 16 Apply a bead of high temperature sealant.

Only venting components manufactured by Vermont Castings, Majestic Products may be used in Direct Vent systems.

## Twist-lock Pipes

When using Vermont Castings, Majestic Products twist-lock pipe it is not necessary to use sealant on the joints. The only areas of the venting system that need to be sealed with high temperature silicone sealant are the collars on the fireplace and the sliding joint of any telescopic vent section used in the system.

To join twist-lock pipes together, simply align the beads of the male end with the grooves of the female end, twisting the pipe until the flange on the female end contacts external flange on the male end. It is recommended that you secure the joints with three (3) sheet metal screws; however, this is not mandatory with twist-lock pipe. (Fig. 17)

To make it easier to assemble the joints we suggest putting a lubricant (Vaseline or similar) on the male end of the twist-lock pipe prior to assembly.

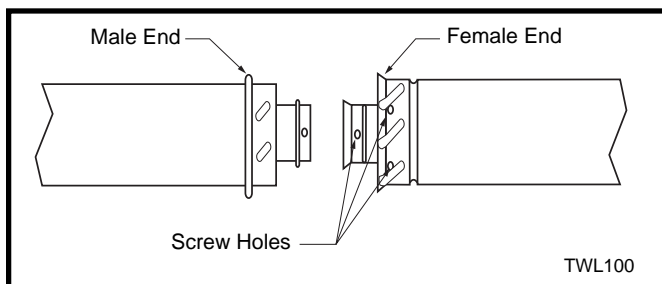

Fig. 17 Twist-lock pipe joints.

## How to Use the Vent Graph

The Vent Graph should be read in conjunction with the following vent installation instructions to determine the relationship between the vertical and horizontal dimensions of the vent system.

1. Determine the height of the center of the horizontal vent pipe exiting through the outer wall. Using this dimension on the Sidewall Vent Graph below, locate the point intersecting with the slanted graph line.
2. From the point of this intersection, draw a vertical line to the bottom of the graph.
3. Select the indicated dimension, and position the fireplace in accordance with same.

### Example A:

If the vertical dimension from the floor of the fireplace is 11' (3.4m), the horizontal run to the face of the outer wall must not exceed 14' (4.3m).

### Example B:

If the vertical dimension from the floor of the unit is 7' (2.14m), the horizontal run to the face of the outer wall must not exceed 8½' (2.6m).

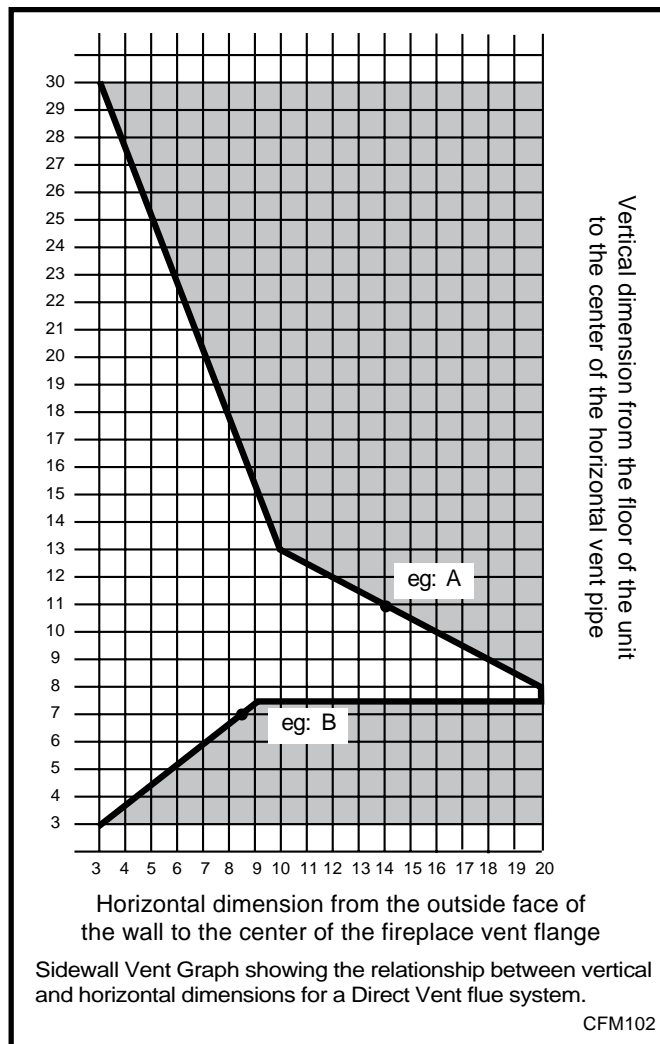

Fig. 18 Sidewall Vent Graph (dimensions in ft.).

## Rear Wall Vent Application

When installed as a rear vent unit this appliance may be vented directly to a termination located on the rear wall behind the appliance.

- Only Vermont Castings, Majestic Products venting components are approved to be used in these applications. See 'Venting Components' listed for different installation requirements.
- The maximum horizontal distance between the rear of the appliance (or end of the transition elbow in a corner application) and the outside face of the rear wall is 20" (508 mm). (Fig. 19)
- Only one 45° elbow is allowed in these installations.
- The minimum clearances between any combustible material and the vent pipe sections are:
 

Top	2" (51mm)
Sides	1" (25mm)
Bottom	1" (25mm)

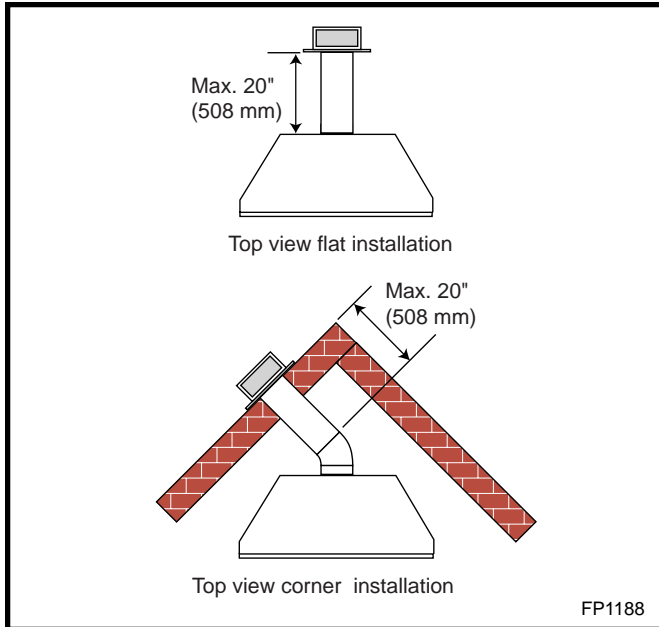

Fig. 19 Rear vent application, maximum horizontal distance.

## Rear Wall Vent Installation

### Step 1

Locate and cut the vent opening in the wall.

For combustible walls, first frame in opening. (Fig. 20)

**Combustible Walls:** Cut a 10 $\frac{3}{8}$ " H x 9 $\frac{3}{8}$ " W (265 x 240mm) hole through the exterior wall and frame as shown.

**Noncombustible Walls:** Hole opening should be 7 $\frac{1}{2}$ " (190mm) in diameter.



**Zero clearance sleeve is required only for combustible walls.**

### Step 2

Measure wall thickness and cut zero clearance sleeve parts to proper length (maximum 12" / 305mm). Assemble sleeve to its maximum opening (10 $\frac{3}{8}$ " x 9 $\frac{3}{8}$ " (265 x 240mm), and attach to firestop with #8 sheet metal screws (supplied). Install firestop assembly. (Fig. 21)

### Step 3

Measure the horizontal length requirement for the venting including a 2" (51mm) overlap; i.e., from the elbow to the outside wall face plus 2" (51mm). (Fig. 19)

### Step 4

Install the 4" (102mm) vent to the appliance collar and secure with 3 sheet metal screws. Install the 7" (175mm) vent pipe to the appliance collar and secure with 3 sheet metal screws. If a 45° elbow is being

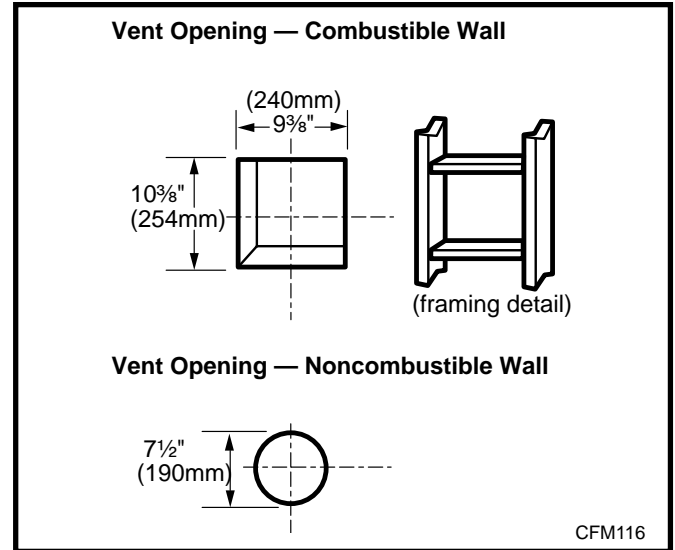

Fig. 20 Vent opening, side wall.

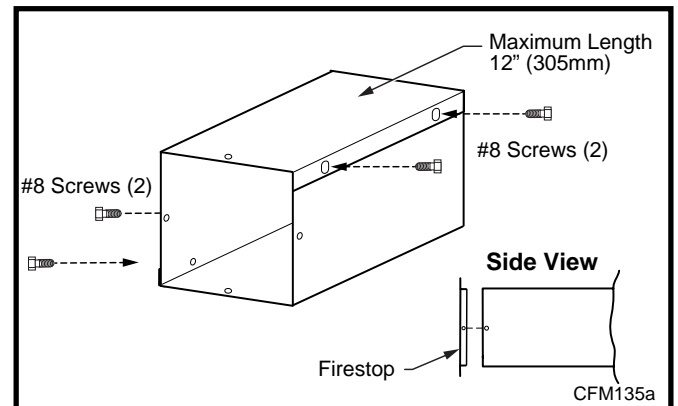

Fig. 21 Adjustable zero clearance sleeve

used, attach the elbow to the appliance with sealant in the same manner then attach the venting to the elbow. It is not necessary to seal the 45° elbow to the starter pipe or termination in the straight out and 45° installation in Figure 19.



**It is critical that there is no downward slope away from the appliance when connecting the vent or elbow.**

### Step 5

Guide the venting through the vent hole as you place the appliance in its installed position. Guide the 4" (102mm) and 7" (175mm) collars of the vent termination into the outer ends of the venting. Do not force the termination. If the vent pipes do not align with the termination, remove and realign the venting at the appliance flue collars. (Fig. 22) Attach the termination to the wall as outlined in the instruction sheet supplied with the termination.

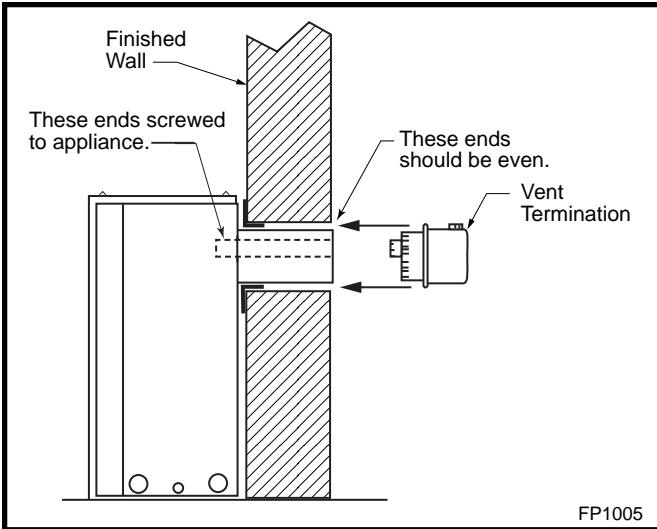

Fig. 22 Flat to the wall installation.

### Vertical Sidewall Application

It is very important the venting system maintain its balance between the combustion air intake and the flue gas exhaust, therefore, certain limitations as to vent configurations apply and must be strictly adhered to.

The Vent Graph (Page 14), showing the relationship between vertical and horizontal side wall venting, will help to determine the various dimensions allowable.

**Minimum clearance between vent pipes and combustible materials is 1" (25mm) on top, bottom and sides unless otherwise noted.**

When vent termination exits through foundations less than 20" (508mm) below siding outcrop, the vent pipe must flush up with the siding.

It is best to position the fireplace so the number of offsets and horizontal vent length are minimized.

The horizontal vent run refers to the total length of vent pipe from the flue collar of the fireplace (or the top of the Transition Elbow) to the face of the outer wall.

Horizontal plane means no vertical rise exists on this portion of the vent assembly.



**When installing the appliance as a rear vent unit, the 90° or 45° transition elbow attached directly to the rear of the unit is NOT INCLUDED in the following criteria and calculations, and unless specifically mentioned, are to be ignored when calculating venting layouts.**

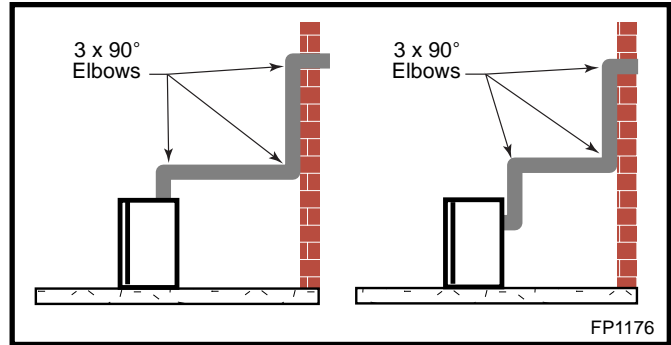

Fig. 23 Maximum three (3) 90° elbows per installation.

- The maximum number of 90° elbows per side wall installation is three (3). (Fig. 23)
- If a 90° elbow is fitted directly on top of the fireplace flange, the maximum horizontal vent run before the termination or a vertical rise is 36 in. (914mm). (Fig. 24)

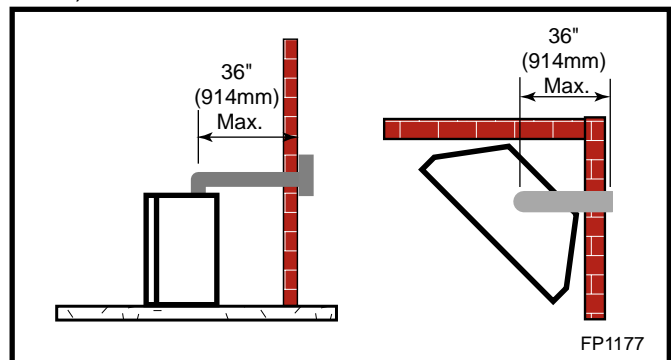

Fig. 24 Maximum horizontal run with no rise.

- If a 90° elbow is used in the horizontal vent run (level height maintained), the horizontal vent length is reduced by 36" (914 mm). (Fig. 25a and Fig. 25b) This does not apply if the 90° elbow is used to increase or redirect a vertical rise. (Fig. 25b)

**Example:** According to the Vent Graph (Page 14), the maximum horizontal vent length in a system with a 7.5' (2.3m) vertical rise is 20' (6m) and if a 90° elbow is required in the horizontal vent it must be reduced to 17' (5.2m).

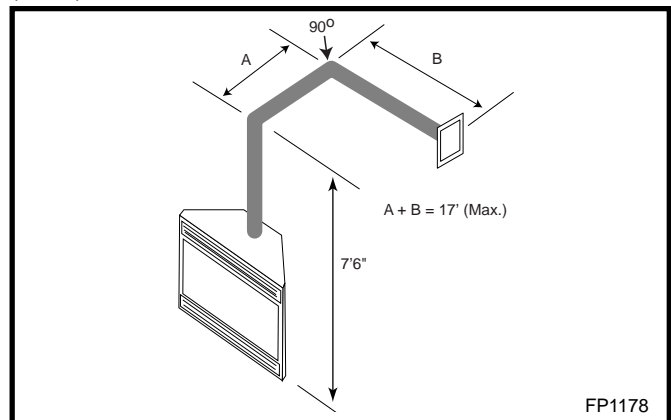

Fig. 25a Horizontal run reduction.



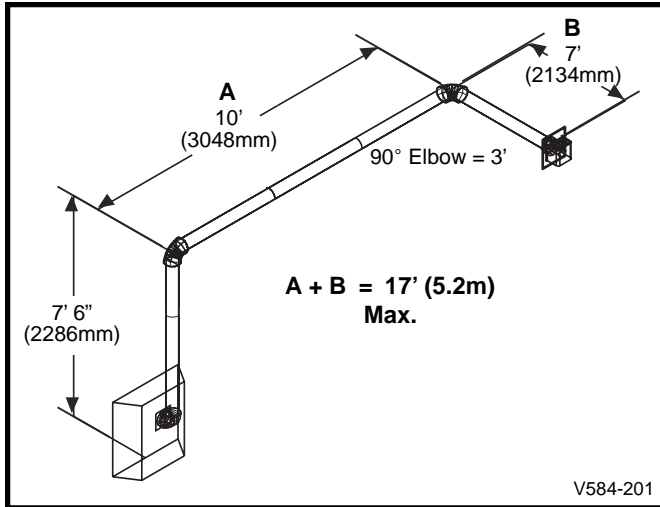

Fig. 25b Maximum vent run with elbows.

In Fig. 25a and Fig. 25b, Dim. A plus Dim. B must not be greater than 17' (5.2m).

- The maximum number of 45° elbows permitted per side wall installation is two (2). These elbows can be installed in either the vertical or horizontal run.
- For each 45° elbow installed in the horizontal run, the length of the horizontal run **MUST** be reduced by 18" (45cm). This does not apply if the 45° elbows are installed on the vertical part of the vent system.
- The maximum number of elbow degrees in a system is 270°. (Fig. 26)

**Example:**

- Elbow 1 = 90°
- Elbow 2 = 45°
- Elbow 3 = 45°
- Elbow 4 = 90°

Total angular variation = 270°

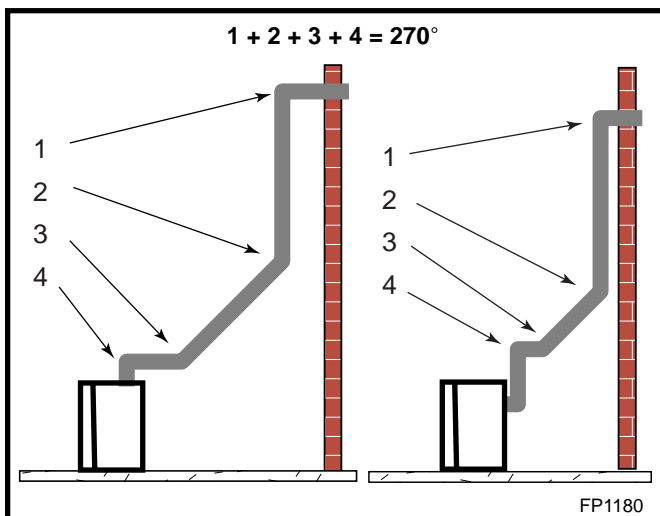

Fig. 26 Maximum elbow usage.

**Vertical Sidewall Installation**

**Step 1**

Locate vent opening on the wall. It may be necessary to first position the fireplace and measure to obtain hole location. Depending on whether the wall is combustible or noncombustible, cut opening to size.

For combustible walls, first frame in opening. (Fig. 27)

**Combustible Walls:** Cut a 9 3/8" H x 9 3/8" W (240 x 240mm) hole through the exterior wall and frame as shown.

**Noncombustible Walls:** Hole opening must be 7 1/2" (190mm) in diameter.

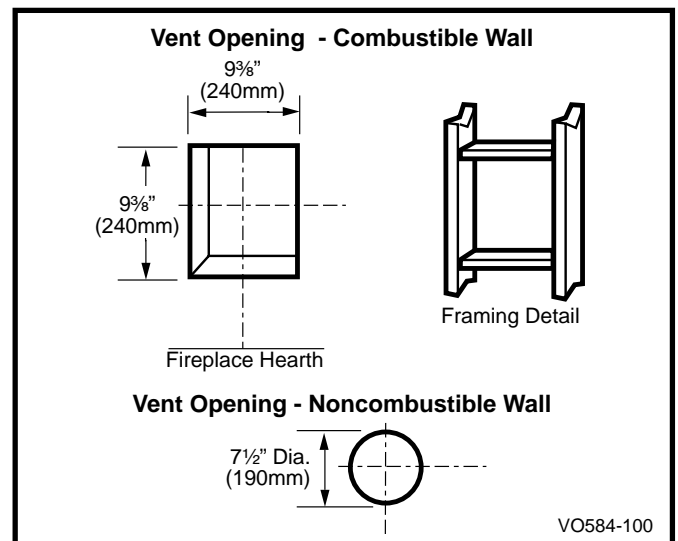

Fig. 27 Locate vent opening on wall.

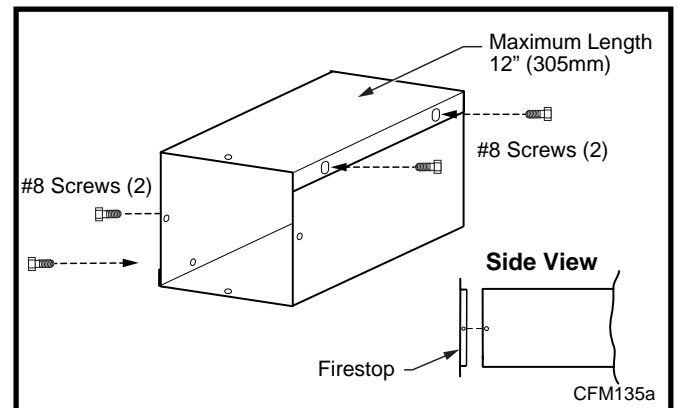

Fig. 28 Adjustable zero clearance sleeve.

**Zero clearance sleeve is required only for combustible walls.**

## Step 2

Measure wall thickness and cut zero clearance sleeve parts to proper length (maximum 12" / 305mm). Assemble sleeve and attach to firestop with #8 sheet metal screws (supplied). Install firestop assembly. (Fig. 28)

## Step 3

Place fireplace into position. Measure the vertical height (X) required from the base of the flue collars to the center of the wall opening. (Fig. 29)

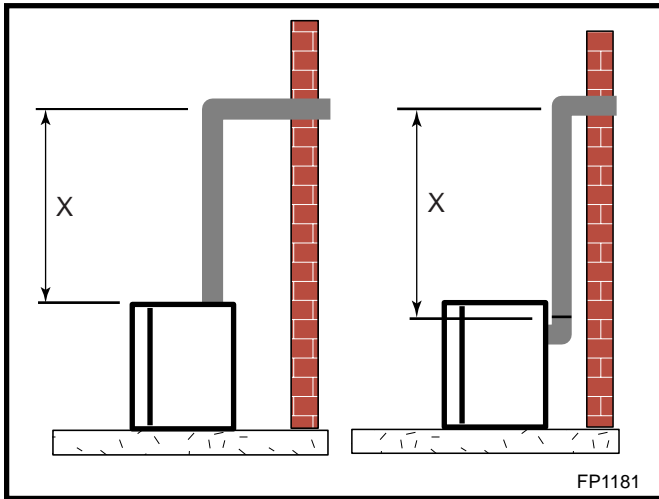

Fig. 29 Vertical height requirements.

## Step 4

Apply a bead of silicone to the inner and outer flue collars of the fireplace and using appropriate length of pipe section(s) attach to fireplace with three (3) screws. Follow with the installation of the inner and outer elbow, again securing joints as described in the 'Connecting Vent Pipe' section.

## Step 5

Measure the horizontal length requirement including a 2" (51mm) overlap; i.e., from the elbow to the outside wall face plus 2" (51mm), or the distance required if installing a second 90° elbow. (Fig. 30)



**Always install horizontal venting on a level plane.**

## Step 6

Use appropriate length of pipe sections, telescopic or fixed, and install. The sections which go through the wall are packaged with the starter kit, and can be cut to suit if necessary.

**NOTE: Sealing vent pipe and firestop gaps with high temperature sealant will restrict cold air being drawn in around fireplace.**

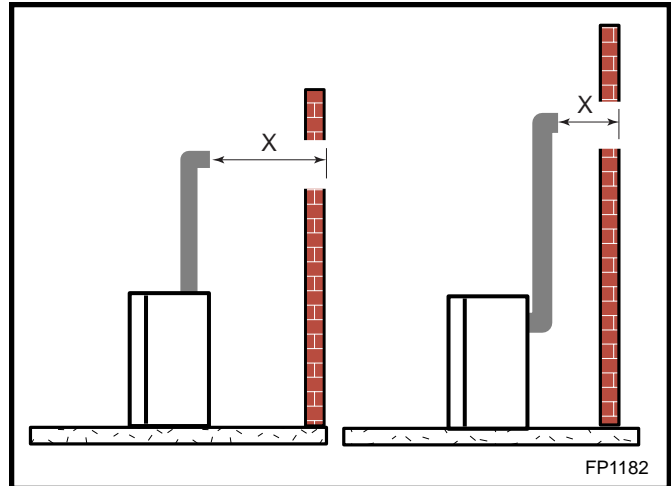

Fig. 30 Horizontal length requirement.

## Step 7

Apply high temperature sealant to the 4" (102mm) and 7" (175mm) collars only. Guide the 4" and 7" collars of the vent termination into their respective vent pipes. Double check that the vent pipes overlap the collars by 2" (51mm). Secure the termination to the wall with screws provided and caulk around the wall plate to weatherproof.

Alternatives to screwing the termination directly to the wall is using either expanding plugs or an approved exterior construction adhesive. Or, you could attach the termination with screws through the inner body into the 4" vent pipe, however, for this latter method, extend the 4" pipe approximately 6" (152mm) beyond the outer face of the wall.



**Support horizontal pipes every 3' (91cm) with metal pipe straps.**

## Below Grade Installation

When it is not possible to meet the required vent terminal clearances of 12" (305mm) above grade level, a snorkel termination is recommended. It allows installation depth down to 7" (178mm) below grade level. The 7" (178mm) is measured from the center of the horizontal vent pipe as it penetrates through the wall.

**NOTE: Ensure that sidewall venting clearances are observed. If venting system is installed below ground, a window well with adequate and proper drainage to be installed around the termination area is recommended.**

If installing a snorkel, a minimum 24" (610mm) vertical rise is necessary. The maximum horizontal run with the 24" (610mm) vertical pipe is 36" (915mm). This measurement is taken from the collar of the fireplace (or transition elbow) to the face of the exterior wall. Refer to the Sidewall Venting Graph for extended horizontal run if the vertical exceeds 24" (610mm).

1. Establish vent hole through the wall. (Page 17, Fig. 27)
2. Remove soil to a depth of approximately 16" (406mm) below base of snorkel. Install drain pipe. Install window well (not supplied). Refill hole with 12" (305mm) of coarse gravel, leaving a clearance of approximately 4" (102mm) below snorkel. (Fig. 31)
3. Install vent system.
4. Ensure a watertight seal is made around the vent pipe coming through the wall.
5. Apply high temperature sealant caulking (supplied) around the 4" and 7" snorkel collars.
6. Slide the snorkel into the vent pipes and secure to the wall.
7. Level the soil so as to maintain a 4" (102mm) clearance below snorkel. (Fig. 31)

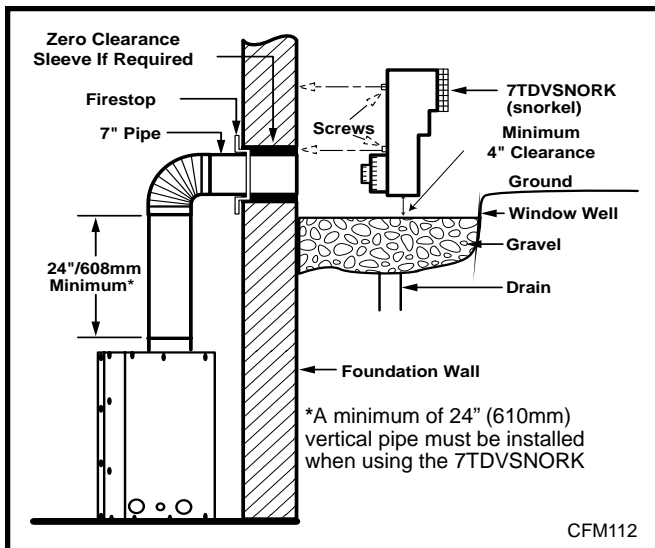

Fig. 31 Below grade installation.



**Do not backfill around snorkel.**

**A clearance of at least 4" (102mm) must be maintained between the snorkel and the soil.**

If the foundation is recessed, use recess brackets (not supplied) for securing lower portion of the snorkel.

Fasten brackets to wall first, then secure to snorkel with self-drilling #8 x 1/2 sheet metal screws. For a recessed foundation wall, it is necessary to extend vent pipes out as far as the protruding wall face. (Fig. 32)

10002428

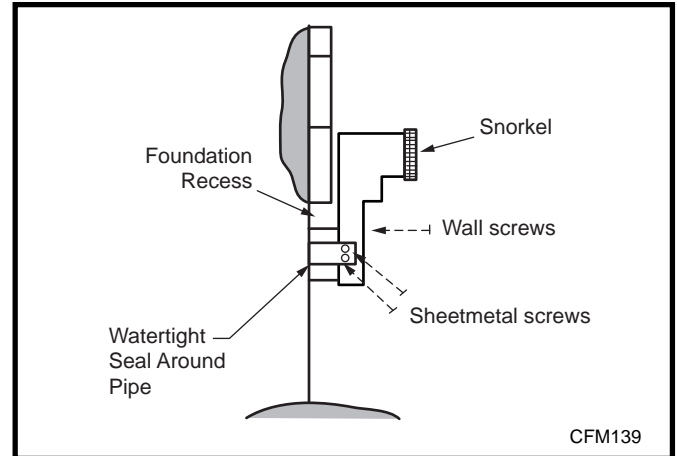

Fig. 32 Snorkel installation, recessed foundation.

### Vertical Through-the-Roof Application

This Gas Fireplace has been approved for:

- Vertical installations up to 40' (12m) in height. Up to a 10' (3m) horizontal vent run can be installed within the vent system using a maximum of two 90° elbows. (Fig. 33)

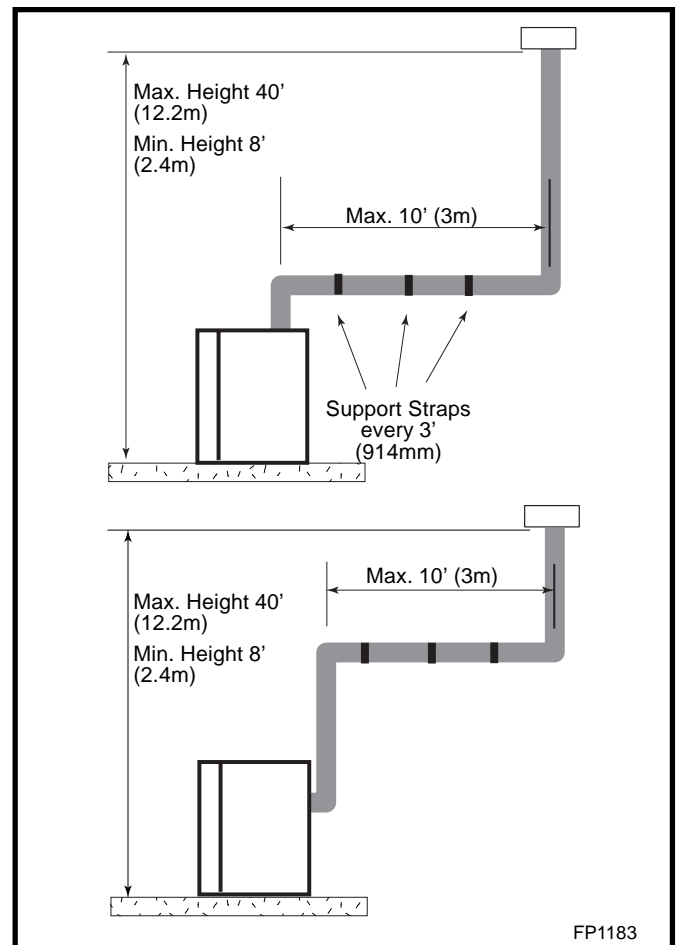

Fig. 33 Support straps for horizontal runs.

- Up to two (2) 45° elbows may be used within the horizontal run. For each 45° elbow used on the horizontal plane, the maximum horizontal length must be reduced by 18" (450mm).
- Example:** Maximum horizontal length
  - No elbows = 10' (3m)
  - 1 x 45° elbows = 8.5' (2.6m)
  - 2 x 45° elbows = 7' (2.1m)
- A minimum of an 8' (2.5m) vertical rise is required.
- Two (2) sets of 45° elbows offsets may be used within the vertical sections. From 0 to a maximum of 8' (2.5m) of vent pipe can be used between elbows. (Fig. 34)
- 7DVCS supports offsets. (Fig. 34) This application requires you to first determine the roof pitch and use the appropriate starter kit. See Venting Components List.
- The maximum angular variation allowed in the system is 270°. (Fig. 34)
- Minimum height of the vent above the highest point of penetration through the roof is 2' (610mm). (Fig. 37) See Note 2 on Page 12.

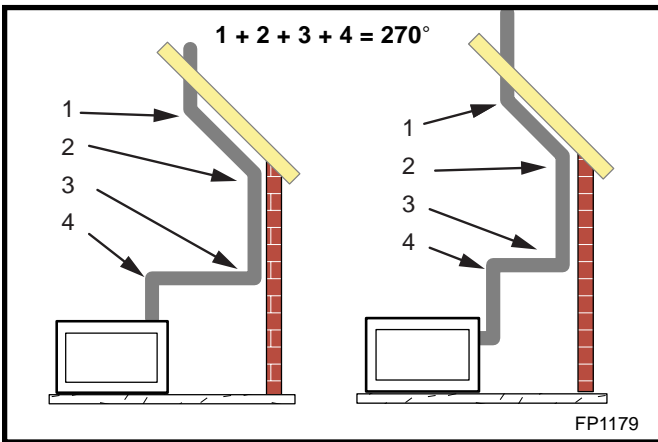

Fig. 34 Maximum elbow usage.

### Vertical Through-the-Roof Installation

1. Locate your fireplace.
2. Plumb to center of the 4" flue collar from ceiling above and mark position.
3. Cut opening equal to 9½" x 9½" (240 x 240mm).
4. Proceed to plumb for additional openings through the roof. In all cases, the opening must provide a minimum of 1" (25mm) clearance to the vent pipe; i.e., the hole must be at least 9½" x 9½" (240 x 240mm).
5. Place fireplace into position.
6. Place firestop(s) #7DVFS or Attic Insulation Shield #7DVAIS into position and secure. (Fig. 35)

7. Install roof support and roof flashing, making sure the upper flange is below the shingles. (Fig. 36)
8. Install appropriate pipe sections until the venting is above the flashing. (Fig. 38)
9. Install storm collar and seal around the pipe.
10. Add additional vent lengths for proper height. (Fig. 37)
11. Apply high temperature sealant to 4" and 7" collars of vertical vent termination and install.



**If there is a room above ceiling level, fire stop spacer must be installed on both the bottom and the top side of the ceiling joists. If an attic is above ceiling level a 7DVAIS (Attic Insulation Shield) must be installed.**

**The enlarged ends of the vent section always face downward.**

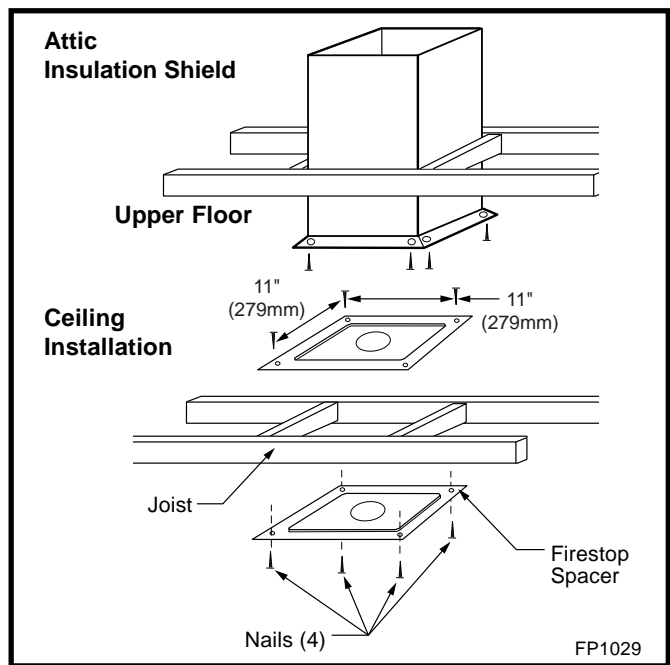

Fig. 35 Attic insulation shield and firestop spacer.

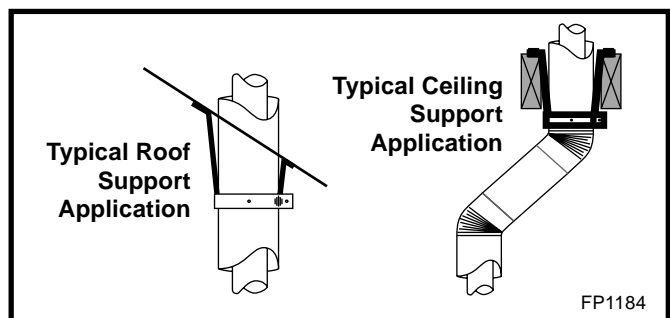

Fig. 36 Venting supports.

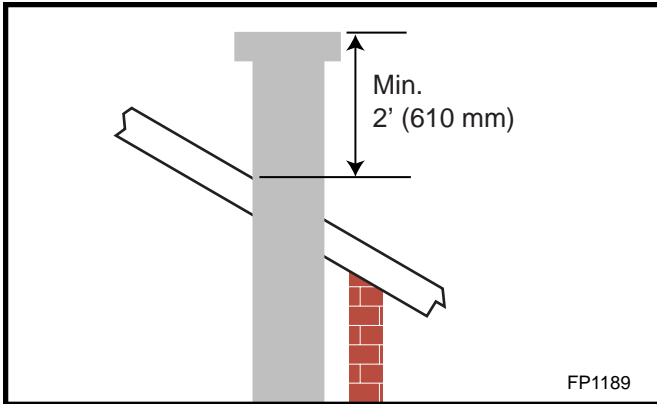

Fig. 37 Minimum termination to roof clearance.

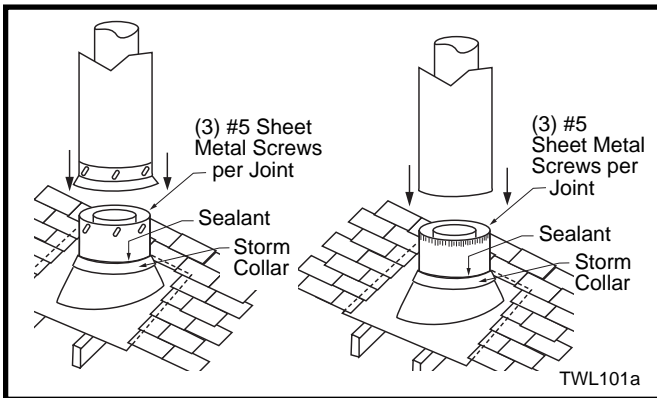

Fig. 38 Roof flashing.

## Gravity Ducting System



**The Gravity Ducting System is only applicable if installing the DVRT43 Direct Vent Fireplace.**

Installation of the **DVRT43** fireplace provides an opportunity to heat either rooms on an upper level or adjacent rooms on the same level without the use of a blower. However, with the internal blower installed, there will be some increase in warm air movement to rooms serviced by the gravity duct. (Fig. 39 and Fig. 40)

1. Plan the gravity duct run first. Use the following graph (Fig. 39) to ensure that the installation meets the recommendations. There is a maximum number of three (3) elbows in a run, however, the run must never go in a downward direction, as this can trap heat in the gravity vent system. Be aware when designing the ducting system that elbows will restrict airflow. Minimize the use of elbows in any installation.
2. It is recommended that the gravity ducting system be installed so that the grilles exit at the same vertical level. If the gravity venting system is installed so the ducting exits at different levels, a chimney effect may occur, resulting in uneven heat distribution.



**Do not discharge directly into a wall or inside an enclosure.**

3. Materials needed for the gravity ducting installation:
  - (2) 5" dia. duct to grille connector boots
  - (2) Wall Outlet grilles
  - 5" dia. rigid ("C" vent) or 5" dia. flexible metal ducting
  - 5" dia. elbows (maximum of 3 per run)
4. Remove the gravity duct plugs from the top of the DVRT43 by taking out the two (2) screws around the perimeter of each plug, then removing the plugs from the fireplace.

**NOTE: Do not remove the center screw from the plugs.**

5. Install 5" rigid (C-Vent) or flexible metal ducting on the DVRT43 and run the ducting, observing the limitations shown in the graph. Be aware that flexible ducting is more restrictive to air flow than rigid ducting.
6. Secure all joints with three (3) sheet metal screws. Seal all joints with foil-faced aluminium tape to prevent heat loss and maintain maximum air flow.
7. Ensure the following clearances are maintained when installing the DVRT43 Gravity Ducting System.

## Clearance to Combustibles

Clearance between ducting and combustibles = 1" (25mm)

Clearance between grille adapter and combustibles = 0" (0mm)



**Never allow a downward slope in any section of the ducting.**

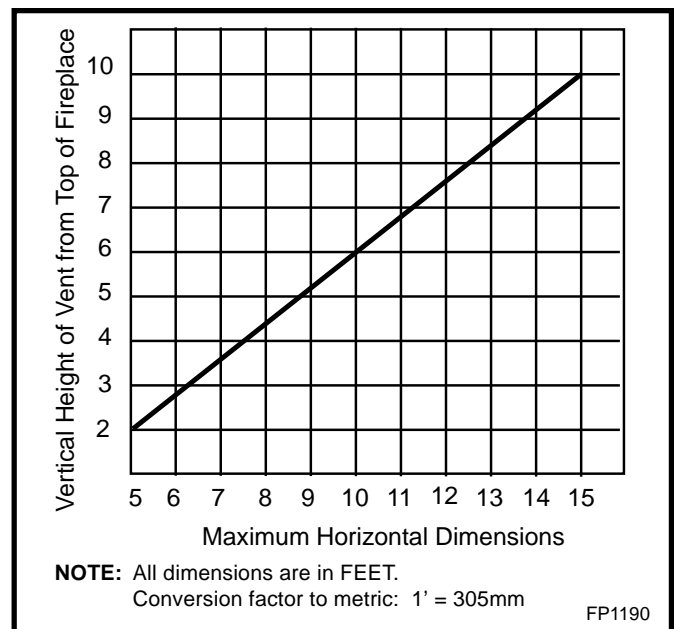
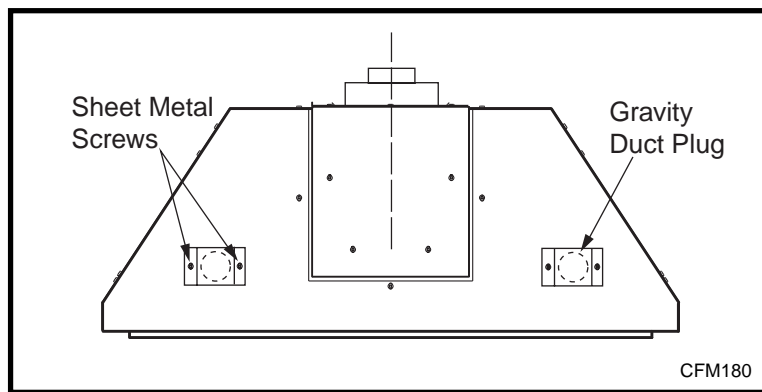
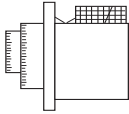
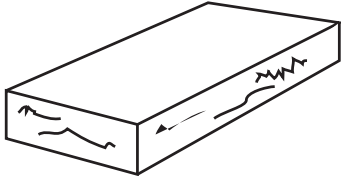
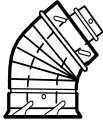
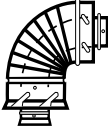
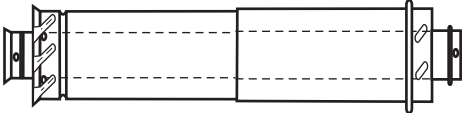
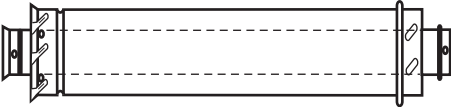
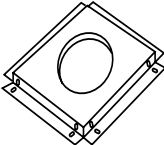
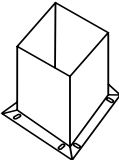
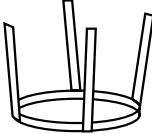
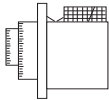
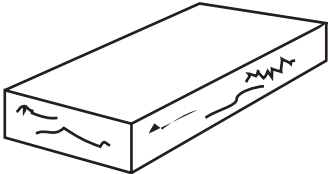

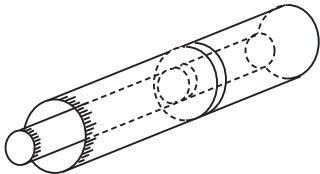
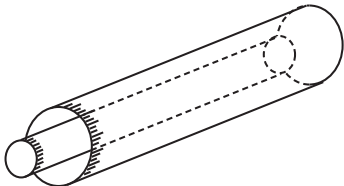
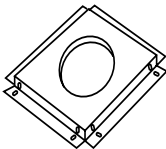
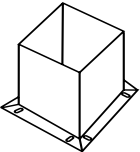
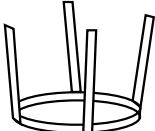

Fig. 39 Gravity vent diagram.



**Fig. 40** Gravity vent locations.

<b>Twist Lock Venting Components</b>	
	7TDVRVT - Through-the-Wall Rear Vent Termination
	Starter Kit - Model 7TDVSK - Sidewall Venting Starter Kit - Model 7TDVSKV - Vertical Venting for 7TDVSKV-A: Order 1/ 12 to 6/ 12 roof pitch for 7TDVSKV-B: Order 7/ 12 to 12/ 12 roof pitch for 7TDSKV-F: Order flat roof Starter Kit - Model 7TDVSKS - Snorkel Kit Snorkel Termination - 7TDVSNORK for Below Grade Installation
	45° Elbow 7TDVT45 for Vertical Installation Offsets 7TDR45 for Rear Vent Application
	90° Transition Elbow 7TDVRT90 for Vertical Sidewall Applications or Through-the-Roof.
	Telescopic Vent Sections 7TDVP1218      12" to 18" adjustable length 7TDVP3564      35" to 64" adjustable length
	Pipe sections for vertical or horizontal venting Model 7TDVP8"            4 per box Model 7TDVP12"          4 per box Model 7TDVP24"          4 per box Model 7TDVP36"          4 per box Model 7TDVP48"
	Firestop Spacer Model 7DVFS
	Attic Insulation Shield Model 7DVAIS
	Vertical/ Horizontal Combination Offset Support Model 7DVCS

<b>Crimped End Venting Components</b>	
	7DVRVT - Through-the-Wall Rear Vent Termination
	Starter Kit - Model 7DVSK - Sidewall Venting Starter Kit - Model 7TDVSKV - Vertical Venting for 7DVSKV-A: Order 1/12 to 6/12 roof pitch for 7DVSKV-B: Order 7/12 to 12/12 roof pitch for 7DSKV-F: Order flat roof Starter Kit - Model 7TDVSKS - Snorkel Kit Snorkel Termination - 7TDVSNORK for Below Grade Installation
	45° Elbow 7DVT45 for Vertical Installation Offsets 7DV45 for Rear Vent Application
	90° Transition Elbow 7DVRT90 for Vertical Sidewall Applications or Through-the-Roof.
	Telescopic Vent Sections: 7DVP610           6" to 10" adjustable length 7DVP1018       10" to 18" adjustable length 7DVP1834       18" to 34" adjustable length 7DVP3466       34" to 66" adjustable length
	Pipe sections for Vertical or Horizontal Venting: Model 7DVP8"           4 per box Model 7DVP12"       4 per box Model 7DVP24"       4 per box Model 7DVP36" Model 7DVP48"
	Firestop Spacer Model 7DVFS
	Attic Insulation Shield Model 7DVAIS
	Vertical/ Horizontal Combination Offset Support Model 7DVCS



## Operating Instructions

### Glass Information



**Only glass approved by Vermont Castings, Majestic Products should be used on this fireplace.**

- The use of any nonapproved replacement glass will void all product warranties.
- Care must be taken to avoid breakage of the glass.
- **Do not operate appliance with glass front removed, cracked or broken.**
- **Replacement glass (complete with gasket) is available through your Vermont Castings, Majestic Products dealer and should be installed only by a licensed qualified service person.**

### Louvre Removal

Remove the louvre assembly top by lifting the panel up and out from the fireplace. (Fig. 41)

The louvre assembly bottom is hinged at the bottom edge and swings down.

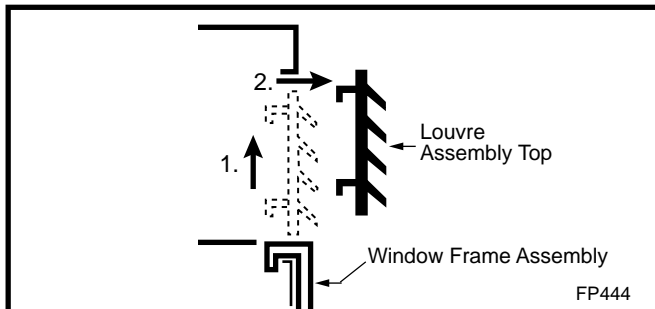

**Fig. 41** Remove louvre assembly top.

### Window Frame Assembly Removal

1. Turn the fireplace OFF (including the pilot).
2. If the unit has been operating, allow time for the components to cool.
3. Remove the louvre assembly top.
4. Open the louvre assembly bottom.
5. Release the two (2) clamps along lower edge of the frame by pulling down on clamp handles. (Fig. 42)
6. Tilt window frame assembly out slightly at the bottom, lift the frame up and away from the fireplace.
7. To replace window frame assembly, reverse this procedure.

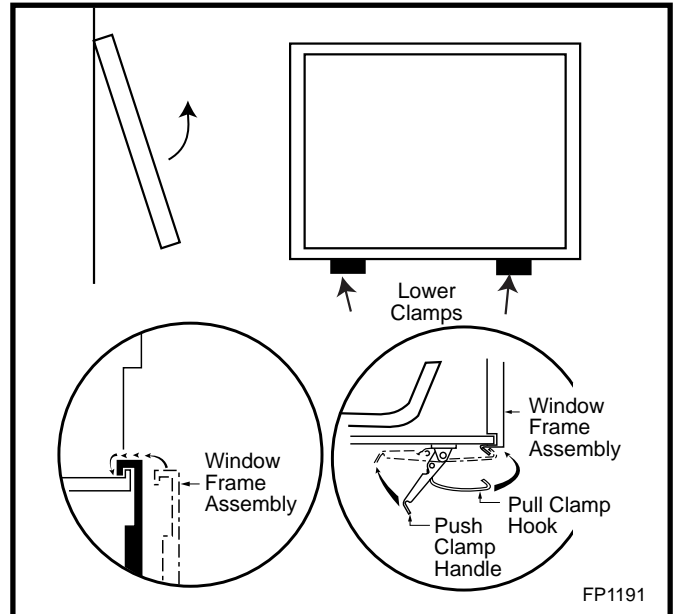

**Fig. 42** Window frame assembly removal.

### Glass Cleaning

It is necessary to periodically clean the glass panel. It is normal for condensation to form on the inside of the glass during start-up. This condensation causes lint, dust, and other airborne particles to cling to glass surface. Also, initial paint curing may deposit a slight film on the glass.

Cleaning the glass two or three times within the first few weeks of operation is recommended, using non-ammonia based household cleaner and warm water, or gas fireplace glass cleaner.

After the initial cleaning process, the glass should be cleaned two or three times during each operating season, depending on the environment in the house.



**Clean the glass after the first two weeks of operation.**

**Do not clean glass when it is hot.**

**Do not use abrasive cleaners.**

**Do not strike or slam the glass.**

## Installation of Logs & Lava Rock

Unpack the logs from their shipping box. Remove each log from its wrapping material.



**Dispose of the plastic bags and wrapping in a safe manner. Keep the logs and plastic bags away from children.**

Take care handling the logs as the material is fragile. The individual logs can be identified by the number cast into the underside of each log.

**DVRT36** - Refer to Figure 43.

1. Remove the top louvre assembly.
2. Remove the window frame assembly.
3. Fit the **left-rear log (B43)** to the left side of the rear log support. The two (2) holes in the log locate on the two (2) studs of the support.
4. Fit the **right-rear log (B31)** to the right side of the support. The two (2) holes in the log locate over the two (2) studs of the support.
5. Fit the **left-front log (B32)** to the support bracket over the burner housing. Again, the two (2) holes in the log locate on the two (2) studs on the bracket.
6. Place the **left-top log (B33)** across the left front and rear logs. (Fig. 43) The hole under the end of this log locates over the knob on the left rear log. The forward end of log B33 rests in the cutout in the left front log.
7. Place the **right-front log (B34)** in position by resting the 'heel' of the log between the outside and first prong of the front grate and laying the log down in the cutout of the right rear log. (Fig. 43)
8. Scatter the **Ceramic Ember Rocks (Part #57897)** over the burner housing assembly in the area forward of the front logs. Refer to shaded areas in Figure 43.
9. Scatter the **lava rock (Part #10001454)** around the base of the firebox area. Do not place any of this material on the burner housing assembly.

**NOTE:** Glowing lava rock for DVRT36 is only allowed to be positioned at the front area (radiant portion) of the burner housing assembly.



**Do not mix the lava rock materials. Lava rock from the package labeled with Part #10001454 must not be placed on the burner housing assembly.**

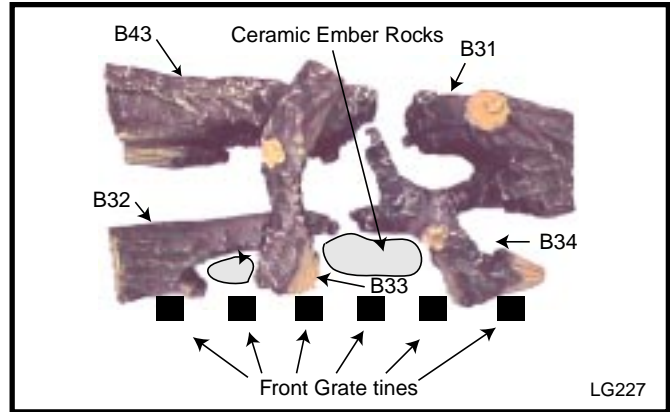

**Fig. 43** DVRT36 logset and ember placement

**DVRT39** - Refer to Figure 44.

1. Remove the top louvre assembly.
2. Remove the window frame assembly.
3. Fit the **rear log (B35)** onto the rear log support. The two (2) holes in the log locate on the two (2) studs on the support.
4. Fit the **right-front log (B36)** onto support bracket over the right side of the burner housing assembly. The two (2) holes in the log locate over the two (2) studs of the bracket.
5. Fit the **left-front log (B37)** onto the support bracket over the left side of the burner housing. Again, the two (2) holes in the log locate on the two (2) studs on the bracket.
6. Place the **left-top log (B38)** in place. The notch along the lower front edge sits against the front grate (Fig. 44), and the top of the log sits in the cutout on the inner end of log B37.
7. Scatter the **Ceramic Ember Rocks (Part #57897)** over the burner housing assembly in the areas between the logs. Refer to shaded areas in Figure 44.
8. Scatter the **lava rock (Part #10001454)** around the base of the firebox area. Do not place any of this material on the burner housing assembly.

**NOTE:** Glowing lava rock for DVRT39 is only allowed to be positioned at the front area (radiant portion) of the burner housing assembly.



**Do not mix the lava rock materials. Lava rock from the package labeled with Part #10001454 must not be placed on the burner housing assembly.**

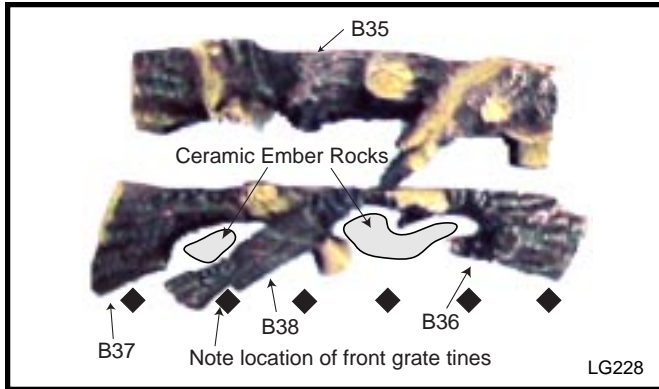

Fig. 44 DVRT39 logset and ember placement

DVRT43 - Refer to Figure 45.

1. Remove the top louvre assembly.
2. Remove the window frame assembly.
3. Install the **right-rear log (B46)** on the rear log support. The two (2) holes in the base of the log locate on the two (2) studs in the log support.
4. Install the **left-rear log (B45)** on the rear log support. The two (2) holes in the base of the log locate on the two (2) studs in the log support.
5. Install the **left-front log (B48)** on the left side of the burner housing. The two (2) holes in the base of the log located over the two (2) studs on the burner housing bracket.
6. Install the **right-front log (B49)** on the right front corner of the burner housing assembly. The notch in the outer end of the log locates against the outermost tine of the front grate.
7. Install the **right-rear top log (B47)**. This log sits on top of the right rear log. It has a rectangular hole on the underside that locates over the rectangular lug on the lower log.
8. Install the **left-front crossover log (B50)**. This log is located over the round knob on top of the left rear log and lays across the cutout on the front left log.
9. Install the **center-front log (B51)**. The hole in the base of this log locates over the stud attached to the front log grate.
10. Scatter the **Ceramic Ember Rocks (Part #57897)** over the burner housing assembly in the area forward of the front logs. Refer to shaded areas in Figure 43.
11. Scatter the **lava rock (Part #10001454)** around the base of the firebox area. Do not place any of this material on the burner housing assembly.

**NOTE: Glowing lava rock for DVRT43 is allowed to be positioned only at the front area (radiant portion) of the burner housing assembly.**



**Do not mix the lava rock materials. Lava rock from the package labeled with Part #10001454 must not be placed on the burner housing assembly.**

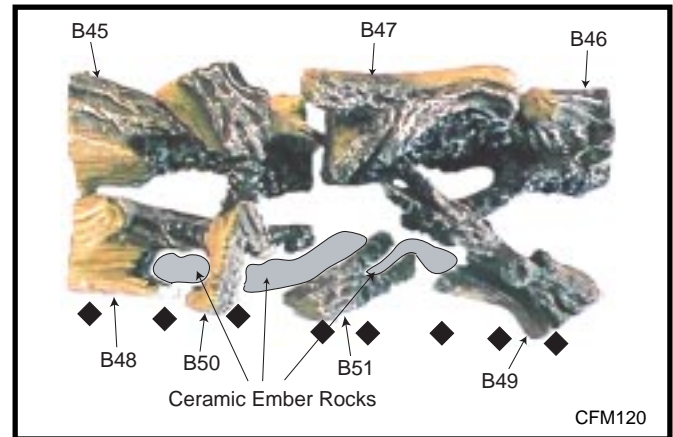

Fig. 45 DVRT43 logset and ember placement.

## Flame & Temperature Adjustment

### RN/RP Models

For units equipped with 'HI/LO' valves the flame adjustment is accomplished by rotating the "HI/LO" adjustments knob located near the center of the gas control valve. (Fig. 46 and Fig. 47)

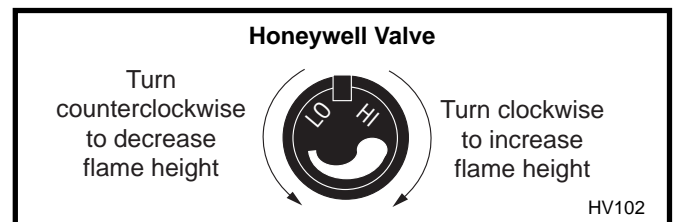

Fig. 46 Flame adjustment knob for Honeywell Valve.

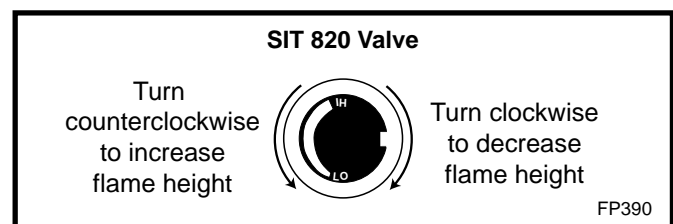

Fig. 47 Flame adjustment knob for SIT Valve.

## Flame Characteristics

It is important to periodically perform a visual check of the pilot and burner flames. Compare to Figure 48 through Figure 51 on Page 28. If the flame patterns appear abnormal, contact a qualified service provider for service and adjustment.

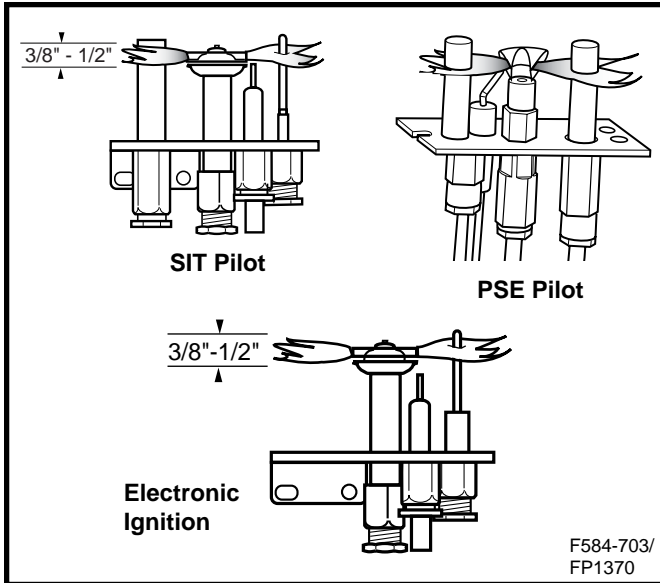

Fig. 48 Correct pilot flame appearance.

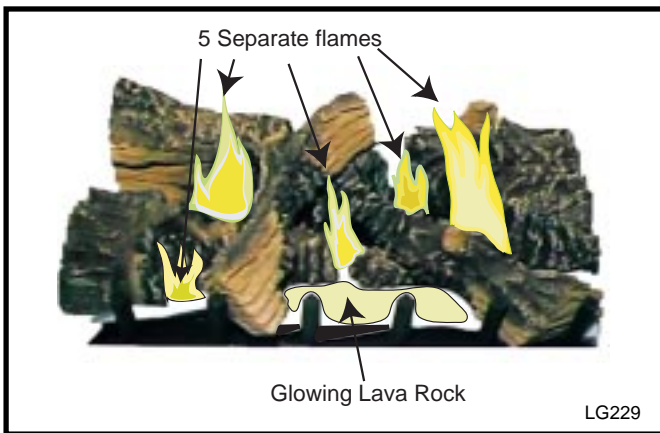

Fig. 49 Correct burner flame appearance for DVRT36.

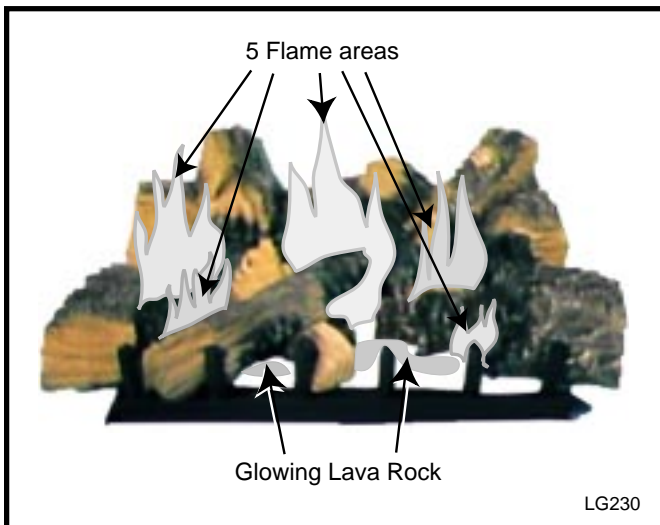

Fig. 50 Correct burner flame appearance for DVRT39.

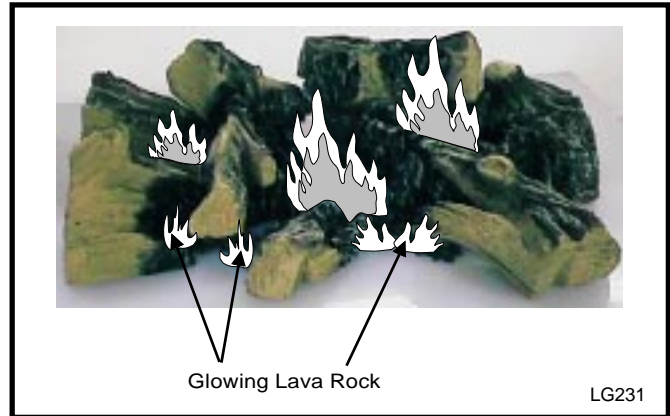

Fig. 51 Correct burner flame appearance for DVRT43.

**NOTE: Glowing lava rock for DVRT36, DVRT39 and DVRT43 is only allowed to be positioned at the front area (radiant portion) of the burner housing assembly.**

### Inspecting the Venting System

This appliance venting system is designed and constructed to develop a positive flow adequate to remove flue gases to the outside atmosphere.

Any foreign objects in the venting system, except those designed specifically for the venting system, may cause spillage of flue gases.

To inspect the venting system, make sure the main gas valve is off. Remove the window frame assembly. (Refer to Window Frame Assembly Removal section.) Using a flashlight, check the area above the baffle in the combustion dome. Clean if necessary.

## Lighting & Operating Instructions

### FOR YOUR SAFETY, READ BEFORE LIGHTING.

**WARNING: If you do not follow these instructions exactly, a fire or explosion may result, causing property damage, personal injury or loss of life.**

- A. This heater has a pilot light, which must be lit manually. When lighting the pilot follow these instructions exactly:
- B. BEFORE LIGHTING, smell all around the heater area for gas. Be sure to smell next to the floor because some gas is heavier than air and will settle on the floor.

#### WHAT TO DO IF YOU SMELL GAS

- Do not try to light any fireplace.
- Do not touch any electric switch.
- Do not use any phone in your building.
- Immediately call your gas supplier from a neighbor's phone. Follow the gas supplier's instructions.

- If you cannot reach your gas supplier, call the Fire Department.

- C. Use only your hand to push in or turn the gas control knob. Never use tools. If the knob will not push in or turn by hand, do not try to repair it, call a qualified service technician. Applying force or any attempted repair may result in a fire or explosion.
- D. Do not use this fireplace if any part has been under water. Immediately call a qualified service technician to inspect the heater and to replace any part of the control system and any gas control which has been under water.

## Lighting Instructions

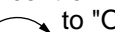
1. **STOP!** Read the safety information above.
2. Turn off all electrical power to the fireplace.
3. For MN/MP/TN/TP appliances ONLY, go on to Step 4. For RN/RP appliances turn the On/Off switch to "OFF" position or set thermostat to lowest level.
4. Open control access panel.
5. Push in gas control knob slightly and turn clockwise  to "OFF".

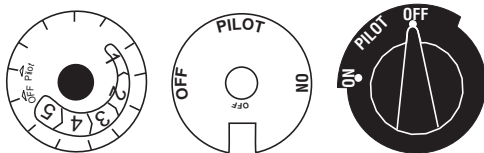

**Euro SIT      SIT NOVA      Honeywell**

6. Wait five (5) minutes to clear out any gas. Then smell for gas, including near the floor. If you smell gas, STOP! Follow "B" in the safety information above. If you do not smell gas, go to the next step.
7. Remove glass door before lighting pilot. (See Glass Frame Removal section).
8. Visibly locate pilot by the main burner.
9. Turn knob on gas control counter-clockwise  to "PILOT".

10. Push the control knob all the way in and hold. Immediately light the pilot by repeatedly depressing the Piezo spark igniter until a flame appears. Continue to hold the control knob in for about one (1) minute after the pilot is lit. Release knob and it will pop back up. Pilot should remain lit. If it goes out, repeat steps 5 through 8.

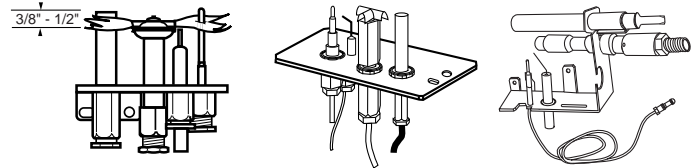

- If knob does not pop up when released, stop and immediately call your service technician or gas supplier.
  - If after several tries, the pilot will not stay lit, turn the gas control knob to "OFF" and call your service technician or gas supplier.
11. Replace glass door.
  12. Turn gas control knob to "ON" position.
  13. For RN/RP appliances turn the On/Off switch to "ON" position or set thermostat to desired setting.
  14. Turn on all electrical power to the fireplace.

## To Turn Off Gas to Heater

1. Turn the On/Off switch to Off position or set the thermostat to lowest setting.
2. Turn off all electric power to the fireplace if service is to be performed.
3. Open control access panel.
4. Push in gas control knob slightly and turn clockwise  to "OFF". Do not force.
5. Close control access panel.

## Lighting & Operating Instructions

### For Fireplaces equipped with SIT822 Gas Valve (EN or EP)

**Warning:** If you do not follow these instructions exactly, a fire or explosion may result, causing property damage, personal injury and loss of life.

### For Your Safety, Read the Following Warnings before Lighting the Appliance

- A. This fireplace is equipped with an ignition device which automatically lights the pilot. **DO NOT** try to light the pilot by hand.
- B. **BEFORE OPERATING**, smell all around the appliance area for gas. Be sure to smell next to the floor because some gas is heavier than the air and will settle on the floor.
  - What to do if you smell gas**
    - **Do not try to light any appliance.**
    - **Do not operate any electrical switch.**
    - **Do not use any phone in your building.**
    - **Immediately call your gas supplier from a neighbor's phone. Follow the gas suppliers instructions.**
- **If you cannot contact your gas supplier call the Fire Department**
- C. Use only your hand to push in or turn the gas control knob. Never use tools. If the knob will not push in or turn by hand do not try to repair it, call a qualified service technician. Force or attempting repair may result in a fire or explosion.
- D. Do not use this appliance if any part has been under water. Immediately call a qualified service technician to inspect the appliance and replace any part of the control system and any gas control that has been under water.

## Lighting Instructions

1. **STOP!** Read the safety information above before continuing.
2. Turn off all electrical power to the appliance.
3. This appliance is equipped with an ignition device which automatically lights the pilot. **DO NOT** try to light the pilot by hand.
4. Access the gas control by lowering the lower access door (louvre assembly).
5. Turn the remote switch, if used, OFF. Turn the wireless remote, if used, OFF.
6. Wait five (5) minutes to clear out any gas. Then smell for gas, including near the floor. If you smell gas, STOP. Follow instruction B in the safety warnings above. If you do not smell gas, go on to the next step.
7. Close the access door.
8. Turn ON all electrical power to the appliance.
9. Turn remote switch or wireless remote to ON.
10. If the appliance will not operate, follow the instructions **TURNING OFF THE GAS TO THE APPLIANCE**, and call your service technician or gas supplier.

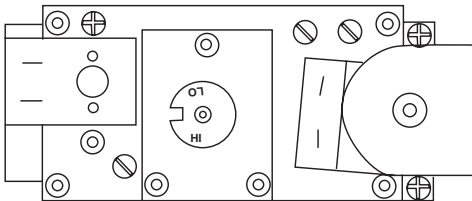

## Turning Off the Gas to the Appliance

1. Turn the remote switch to the OFF position.
2. Turn OFF all electrical power to the fireplace if service is required.
3. Open the lower access panel.
4. Turn the shut-off valve on the flexible gas line to the OFF position.

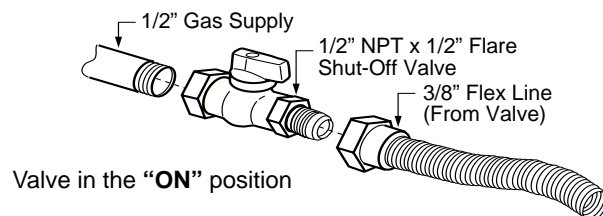

## Instructions for RF Comfort Control Valve

The Comfort Control Valve allows remote control of temperature, fan and flame appearance.

**NOTE:** The antenna should hang in free air away from grounded metal.

## Operation of RF Comfort Control Valve

1. If the manual switch is in remote position, switch it to **LOCAL**. (Fig. 52)
2. Turn the pilotstat knob counterclockwise from **OFF** to the **PILOT** position, push the knob down, and hold in position. The pilot valve opens and allows gas to flow to the pilot burner.
3. Push plunger on the piezo until the pilot burner is lit. When the pilot burner is lit, the **LED** on the control will come on after approximately 40 seconds and will provide one short blink continuously in the normal mode. When the light turns off (approximately 10 seconds after it has been continuously red), the receiver/valve is fully powered.
4. Release the knob. The shaft will move upward. The pilot burner should now stay burning. If the pilot burner goes out, repeat Step 2.
5. Turn the knob counterclockwise to the **ON** position. If the manual switch is in the **LOCAL** position, the main burner will turn on immediately.
6. Upon initial use of a transmitter, a recognition operation is required between the receiver/valve and transmitter. Change the switch from **LOCAL** to **REMOTE**. Press the fan or flame button on the transmitter within 30 seconds. The **LED** will blink indicating the transmitter will now work with the receiver/ valve. If the switch continues in the **REMOTE** position, the transmitter will now control the main valve, flame modulation level, and fan control.

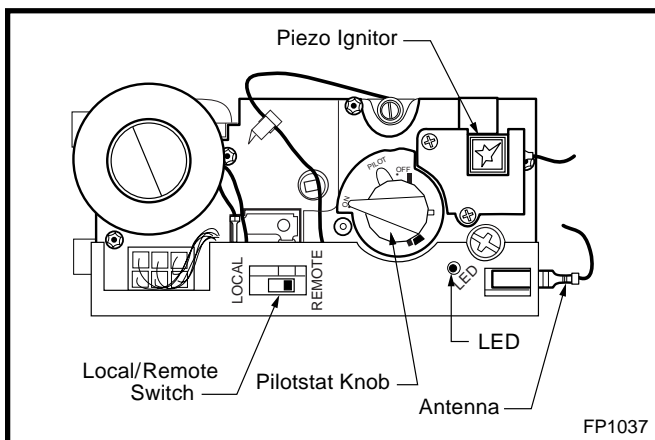

Fig. 52 Comfort control valve.

7. If the manual switch is in the **LOCAL** position, the valve will be at the highest fixed pressure setting and the fan will be at the highest fixed speed. The transmitter will control the fan only.

## Shutoff Procedure

If the manual switch is in the **REMOTE** position, the transmitter can shut off the main burner and fan. However, the control is still on and a command from the transmitter can turn on the main burner or fan.

To shut off the system, turn the pilotstat knob clockwise to the **OFF** position. This action closes the main gas and safety valves. The transmitter cannot turn on the main burner or fan.

## Transmitter Operation

Refer to Figure 53.

### OFF Mode

In the **OFF** mode, the fireplace flame and fan are off, the display will show **OFF** and displays the room temperature. If the receiver is in **REMOTE** mode, the fireplace will shut off.

### ON (Manual) Mode

In the **ON** mode, the room temperature, flame and fan levels will be shown. **MANUAL** will appear next to both the flame and fan icons.

When the control is in the **ON** mode, the flame levels, fan levels, and delay timer are changed with the up and down buttons. To change the flame level, press the flame button followed by an arrow key. To change the fan level, press the fan key followed by an arrow key. Pushing the arrow key once will change the level by one unit.

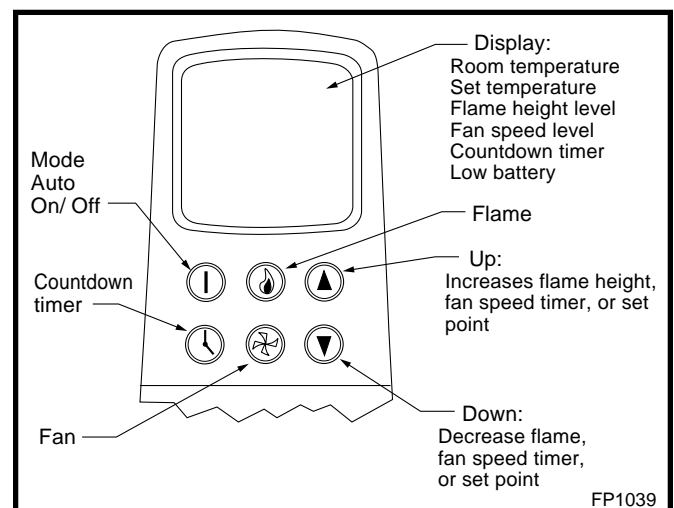

Fig. 53 Transmitter diagram.

### Delay Time Mode

The shutoff delay timer has a maximum of two (2) hours, and a minimum of zero (0) minutes. To change the timer level, press the timer key, then an arrow key. Pushing the key once changes the timer by ten minutes.

### Auto Mode

In the **AUTO** mode, the room temperature, set temperature, flame and fan levels will be shown. **AUTO** will appear next to both flame and fan icons.

When the control is in the **AUTO** mode, the main burner will turn On/Off or modulate based on the heat needed to maintain the set temperature. The flame level will change automatically to optimize the heat output needed to maintain the set temperature. To change the set temperature, press the up or down key. Pushing a key once will change the temperature by one degree.

In the **AUTO** mode, the fan speed will increase with increasing flame height or decrease with decreasing flame height. **AUTO** is displayed next to the flame and fan icons.

### Fan Override During Automode

If a lower or higher fan speed is desired when operating in the **AUTO** mode, the fan speed can be overridden by pushing the fan button followed by the up or down key. Pushing a key once will change the fan level by one unit. In this mode **AUTO** is displayed next to the flame icon and **MANUAL** is displayed next to the fan icon.

### Toggle Between °F/°C Temp. Units

Push the Up and Down arrow keys simultaneously for at least three (3) seconds to toggle between Fahrenheit and Celsius units.

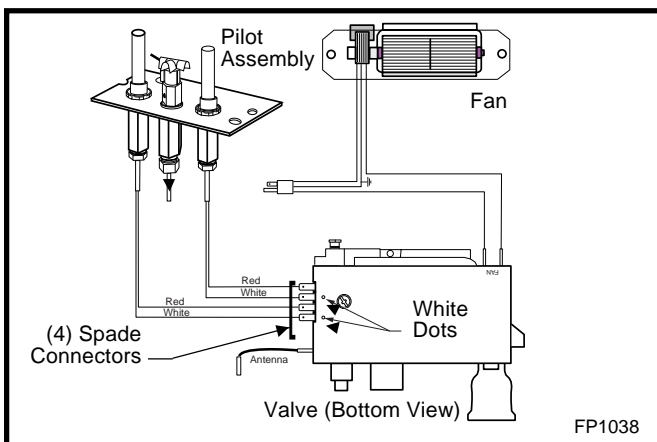

Fig. 54 Comfort Valve wiring diagram.

### Disable Thermostat Function

To disable the thermostat function in the **AUTO** mode, push the **TIME** and **DOWN** keys simultaneously for at least three (3) seconds.

### To Change Batteries

1. Remove cover on backside of the transmitter. Install three (3) AAA batteries as shown and reattach cover.
2. Once steps 1 to 3 in **OPERATION** are completed, receiver/valve and transmitter are ready. Press any button on transmitter for recognition process to occur between the receiver/valve and transmitter.
3. Use functions as described in **TRANSMITTER** section.

### Troubleshooting RF Comfort Control Valve

1. Locate **LED** light on valve. (Fig. 52)
2. **LED** will blink after every valid command received by the transmitter; this is not an error.
3. Failure codes may occur any time after pilot burner is lit.
4. Sequence is failure code followed by **LED** not blinking for 30 seconds.
5. In the event of multiple failure codes, next failure code follows previous failure code by approximately three seconds.

**If Error Code 3 is observed while performing the testing, complete the following:**

1. Make sure the spade connectors are pushed all the way on. (Fig. 54) If Error Code 3 is still showing, go to the next step.
2. Switch the front two thermopile leads with the back two leads. (Be sure the white leads are connected to the spades with white dots next to them.) If Error Code 3 is still showing, replace the thermopiles.

**If Error Code 8 is observed while performing the testing, complete the following:**

1. Confirm the valve is not in **REMOTE** mode. (Fig. 52)
  - If the valve is producing Error Code 8 and in **REMOTE** mode, the valve is defective and should be replaced.
  - If the valve is in **LOCAL** mode and producing Error Code 8, then go to the next step.
2. Slide the Remote/Local switch to **REMOTE** and program the transmitter per Item 6, Page 31. The Error Code will clear itself after approximately 1.5 minutes and return to normal operation.



## Auto Path Chart

LED Count	Service Action
8	Replace valve
7	Confirm stepper motor connection exists
5	Confirm fan connection exists and works
4	Confirm gas type; jumper in place
3	Replace thermopiles
2	Turn fan ON

**NOTE:** Some keys are not active.

### Auto Path

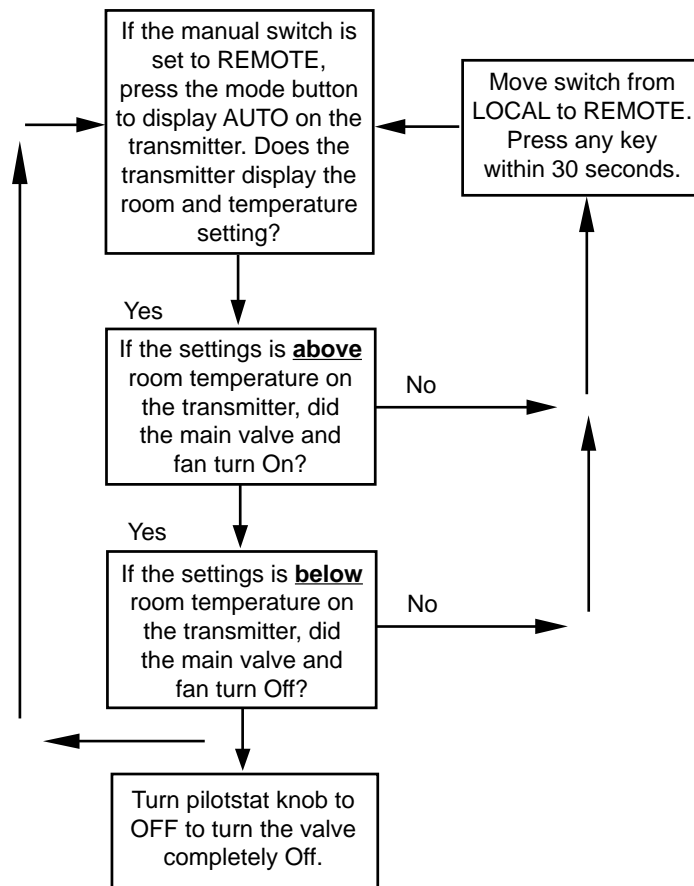

## Comfort Valve System Control Sequence of Operation with Transmitter

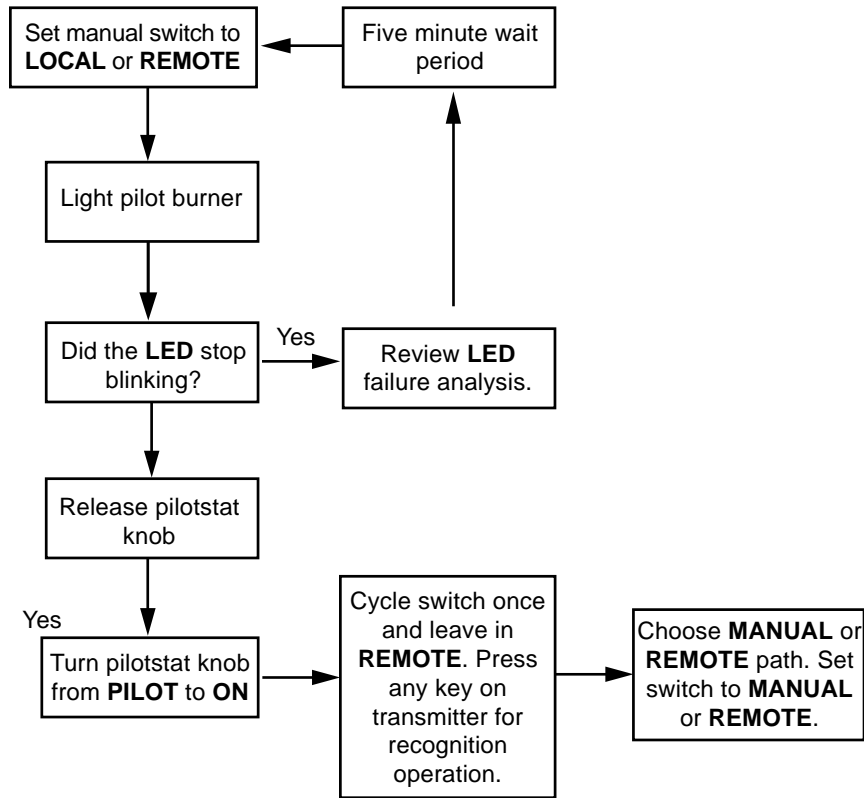

### Local Path

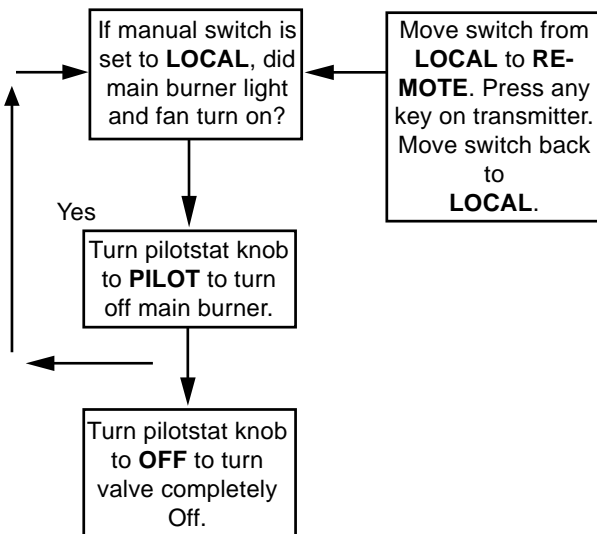

### On Path

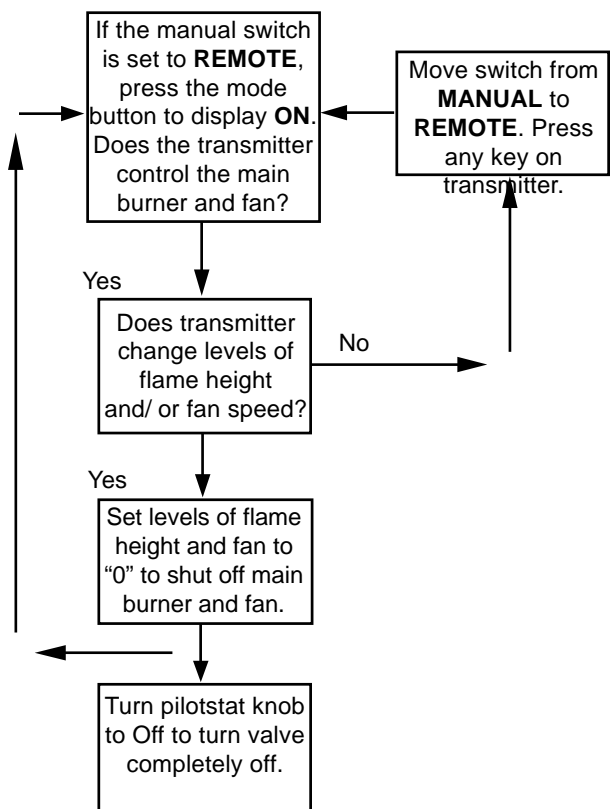

# Troubleshooting – Honeywell VS8421



Remove the Window Frame Assembly before service work.

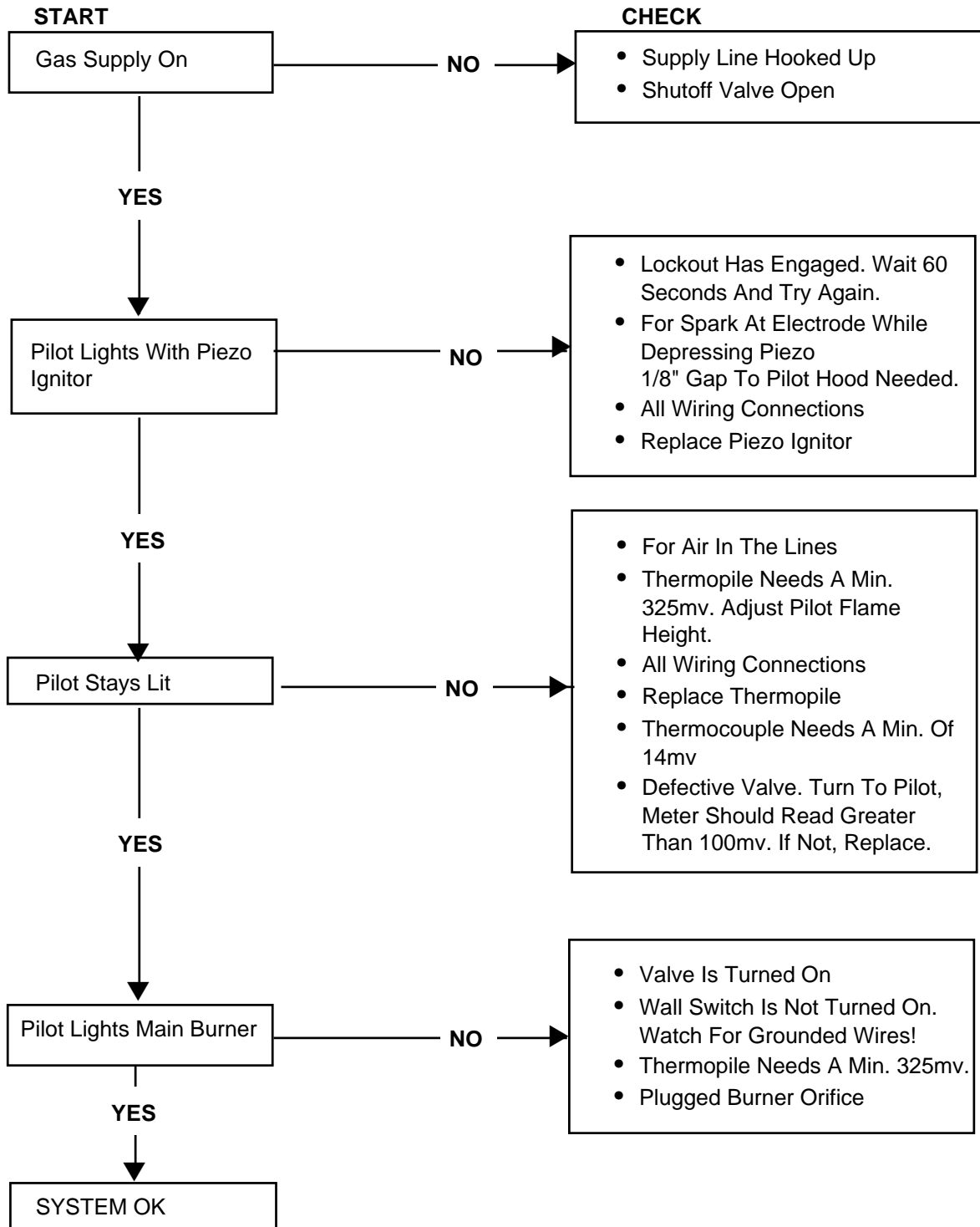

## Troubleshooting the Gas Control System

### SIT NOVA 820 MILLIVOLT VALVE

**Note:** Before trouble shooting the gas control system, be sure external gas shut off is in the “ON” position.

**WARNING:** BEFORE DOING ANY GAS CONTROL SERVICE WORK, REMOVE GLASS FRONT.

SYMPTOM	POSSIBLE CAUSES	CORRECTIVE ACTION
1. Spark ignitor will not light.	A. Defective or misaligned electrode at pilot	Using a match, light pilot. If pilot lights, turn off pilot and push the red button again. If pilot will not light, check gap at electrode and pilot; it should be 1/8 in. to have a strong spark.
	B. Defective ignitor (Push Button)	Push Piezo Ignitor Button. Check for spark at electrode and pilot. If no spark to pilot, and electrode wire is properly connected, replace ignitor.
2. Pilot will not stay lit after carefully following lighting instructions.	A. Defective pilot generator (thermocouple); remote wall switch	Check pilot flame. Must impinge on thermocouple/thermopile. NOTE: This pilot burner assembly utilizes both—a thermocouple and a thermopile. The thermocouple operates the main valve operation (On and Off). Clean and/or adjust pilot for maximum flame impingement on thermopile and thermocouple.
	B. Defective automatic valve	Turn valve knob to “Pilot.” Maintain flow to pilot; millivolt meter should read greater than 10 mV. If the reading is okay and the pilot does not stay On, replace the gas valve. NOTE: An interrupter block (not supplied) must be used to conduct this test.
3. Pilot burning; no gas to main burner	A. Wall switch or wires defective	Check wall switch and wires for proper connections. Jumper wire across terminals at wall switch; if burner comes on, replace defective wall switch. If okay, jumper wires across wall switch wires at valve. If burner comes on, wires are faulty or connections are bad.
	B. Thermopile may not be generating sufficient millivoltage	<ol style="list-style-type: none"> <li>1. Be sure wire connections from thermopile at gas valve terminals are tight and thermopile is fully inserted into pilot bracket.</li> <li>2. One of the wall switch wires may be grounded. Remove wall switch wires from valve terminals; if pilot now stays lit, trace wall switch wiring for ground. May be grounded to fireplace or gas supply.</li> <li>3. Check thermopile with millivolt meter. Take reading at thermopile terminals of gas valve. Should read 250–300 millivolts (minimum 150) while holding valve knob depressed in pilot position and wall switch “Off.” Replace faulty thermopile if reading is below specified minimum.</li> </ol>
	C. Plugged burner orifice	Check burner orifices for debris and remove.
	D. Defective automatic valve operator	Turn valve knob to “On;” place wall switch to “On.” Millivolt meter should read greater than 100 mV. If the reading is okay and the burner does not come On, replace the gas valve.
4. Frequent pilot outage problem	A. Pilot flame may be too low or blowing (high), causing the pilot safety to drop out.	Clean and/or adjust pilot flame for maximum flame impingement on thermopile and thermocouple.
	B. Possible blockage of the vent terminal	Check the vent terminal for blockage (recycling the flue gases).

## Troubleshooting the Gas Control System

### SIT 822 Valve with a Honeywell Electronic Igniter

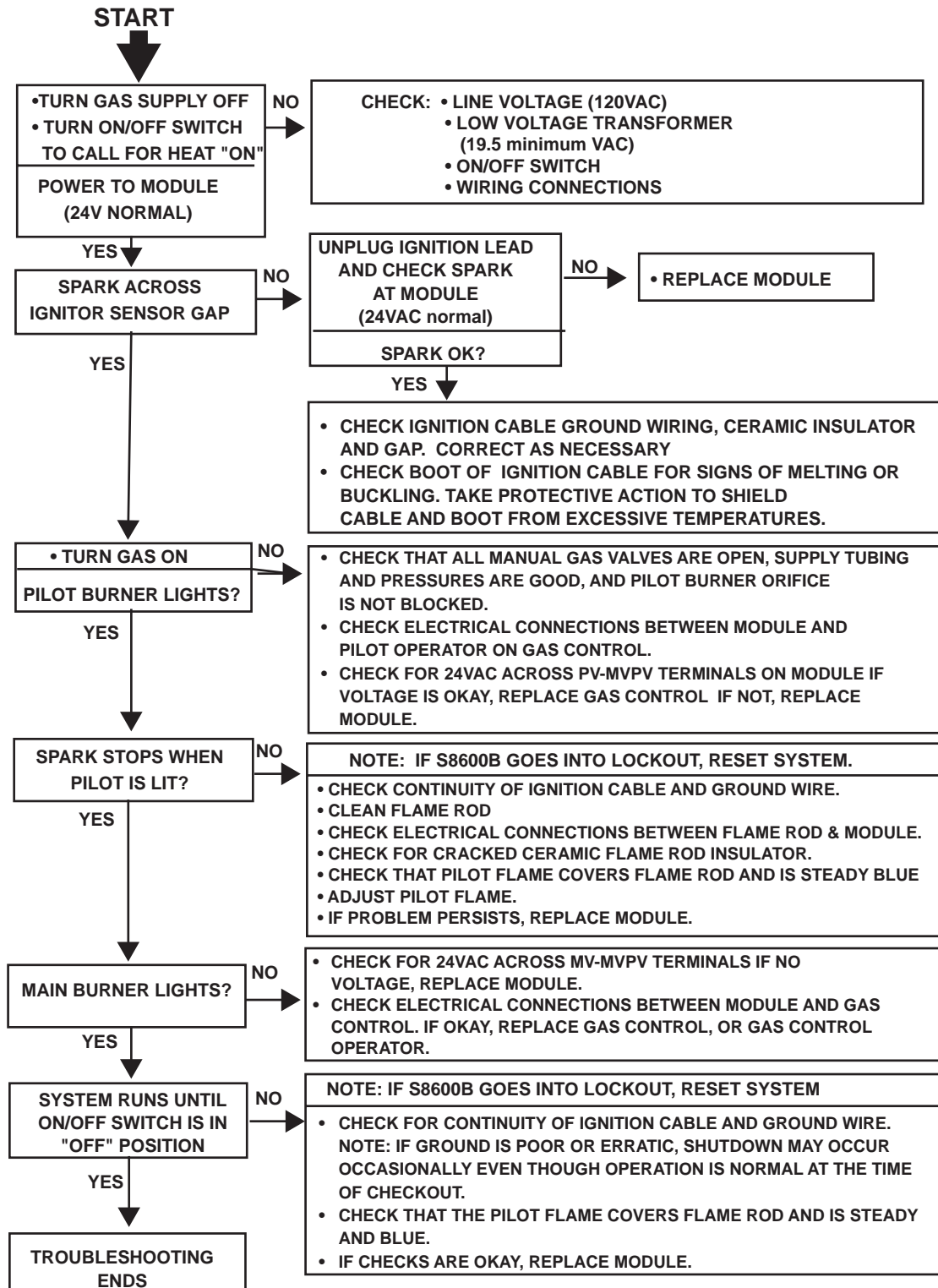

## Fuel Conversion Instructions



The conversion of this appliance from one gas to another must be carried out by an authorized service provider.

1. Disconnect power to unit and shut off the gas supply.
2. Remove the glass (see 'Window Frame Assembly Removal' Section).
3. Carefully remove the logs and lava rock material.
4. Remove the pilot assembly from the bracket.
5. Remove the screws that are holding the burner housing assembly in place.
6. Remove the burner housing assembly.
7. Remove front and rear orifice and replace with the orifice supplied in the conversion kit. Use the orifice with the smallest hole for the front burner and the orifice with the largest hole for the rear burner.

**NOTE: On the DVRT43 (only), the adjustable air shutter on the end burner housing must be replaced. Refer to the instructions in the specific gas conversion kit for details.**

### 8. SIT Top Convertible Pilot

Gently lift off pilot hood from the pilot. (Do not remove the spring clip holding the hood in place). Using a correct size Allen key, unscrew the exposed orifice. Insert the new orifice supplied in the kit; do not overtighten the orifice. Replace the pilot hood ensuring the index tab aligns with the notch on the hood.

### PSE Pilot

Using a suitable wrench on the hexagonal body unscrew the pilot hood assembly from the pilot, **do not twist the hood itself**. Remove the orifice and replace it with the new orifice supplied in the kit. Refit the pilot hood assembly. **Do not overtighten the pilot hood. The hood must return to its original alignment. Take care not to damage the thermocouple, thermopile or igniter.**

### 9. SIT 820 NOVA Gas Control Valve (Fig. 55)

- a) Using a Torx T20 or slotted screwdriver, remove and save (3) pressure regulator mounting screws (A), pressure regulator tower (B), and diaphragm (C).
- b) Ensure the rubber gasket (D) is properly positioned and install the new **HI/LO** pressure regulator to valve using the new screws (E) supplied with the kit. Tighten screws securely. (Reference torque: 25 in-lb)
- c) Install the enclosed identification label (F) to the valve body where it can be easily seen.

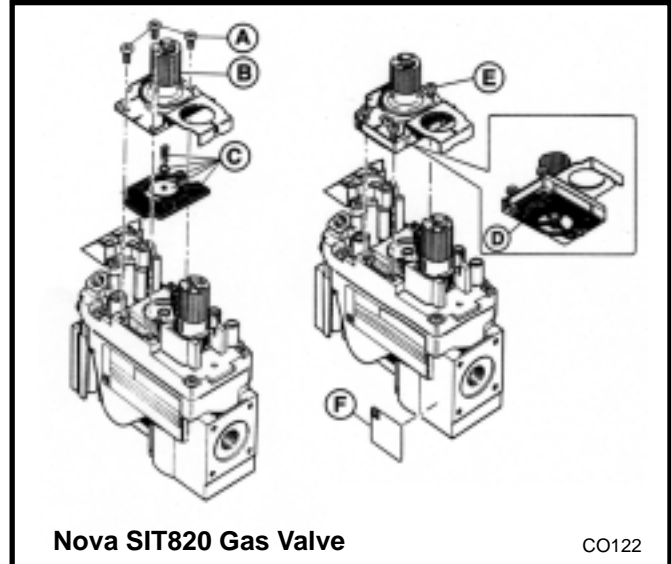

Fig. 55 Nova SIT 820 gas valve conversion.

### Honeywell Gas Control Valve (Fig. 56)

The Honeywell valve fitted to this unit is suitable for use with LP or Natural Gas. It is converted to the required gas application by installation of a color coded "conversion screw."

- a) Using a suitable small screwdriver lift out the central regulator cap from the **HI/LO** knob on the valve.
  - b) Unscrew the exposed conversion screw.
  - c) Insert the new color coded conversion screw. **Do not overtighten the screw; it must be finger tight.**
  - d) Refit the regulator cap.
  - e) Mount conversion label supplied with conversion screw to valve in a visible position.
10. Reassemble fireplace in the reverse order, except window frame assembly. Leave this off until after unit has been checked for leaks and the gas supply has been bled.
  11. After bleeding gas line and checking for leaks with a soap solution, replace the front glass. Fire up the unit, check for flame impingement on logs, adjusting them if necessary. Check manifold and supply pressures against the appliance specifications.



The procedure for converting from one gas to another is the same regardless of the initial gas used. The only variation is in the orifice sizes and component part numbers. Your authorized service provider will ensure correct parts are used.

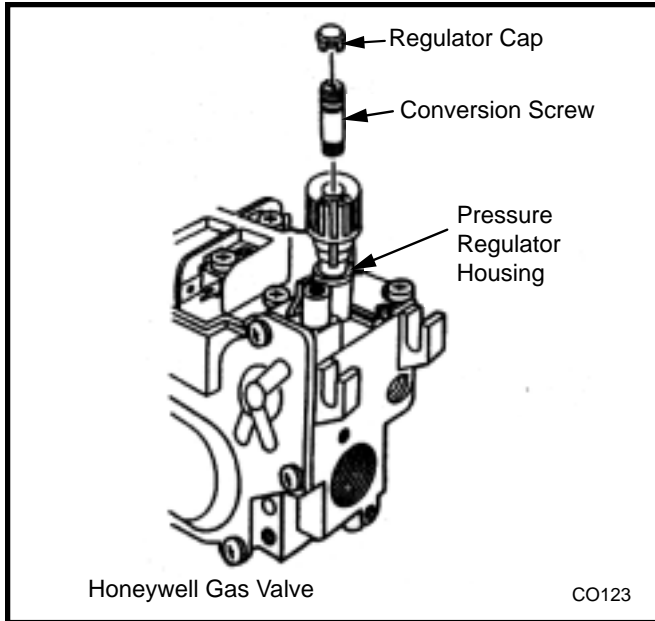

Fig. 56 Honeywell gas valve conversion.

## Maintenance

### Burner and Burner Compartment

It is important to keep the burner and the burner compartment clean. At least once per year the logs and lava rock/ember material should be removed and the burner compartment vacuumed and wiped out. Remove and replace the logs as per the instructions in this manual.

### FK-24/FK-12 Fan Assembly

The fan unit requires periodic cleaning. At least once per month in the operating season, open the lower louver panels and wipe or vacuum the area around the fan to remove any buildup of dust or lint.

### Brass Trim

Clean the brass trim pieces using a soft cloth lightly dampened with lemon oil. Do not use water or household cleaners on any brass components.

Contact your local representative to arrange an annual service program.

## Cleaning the Standing Pilot Control System

The burner and control system consists of:

- burner housing
- pilot assembly
- millivolt gas valve
- gas orifice
- thermopile

Most of these components may require only an occasional checkup and cleaning and some may require adjustment. **If repair is necessary, it should be performed by a qualified technician.**

1. Turn off pilot light at gas valve side.
2. Let fireplace cool if it has been running.
3. Remove window frame assembly. (Refer to 'Window Frame Assembly Removal' section.)
4. Remove logs.
5. Vacuum burner compartment especially around orifice primary air openings.
6. Visually inspect pilot. Brush or blow away any dust or lint accumulation.
7. Reinstall logs.
8. Ignite pilot. Refer to 'Lighting Instructions'.
9. Reinstall window frame assembly.

To obtain proper operation, it is imperative that the pilot and burner's flame characteristics are steady, not lifting or floating.

Typically, the top 3/8" to 1/2" of the thermopile should be engulfed in the pilot flame. Refer to Page 28, Figure 48.

To adjust pilot burner (by qualified service technician):

1. Remove pilot adjustment cap.
2. Adjust pilot screw to provide properly sized flame.
3. Replace pilot adjustment cap.

The primary air shutter is set at factory and should be adjusted, if necessary, only by a qualified service technician.

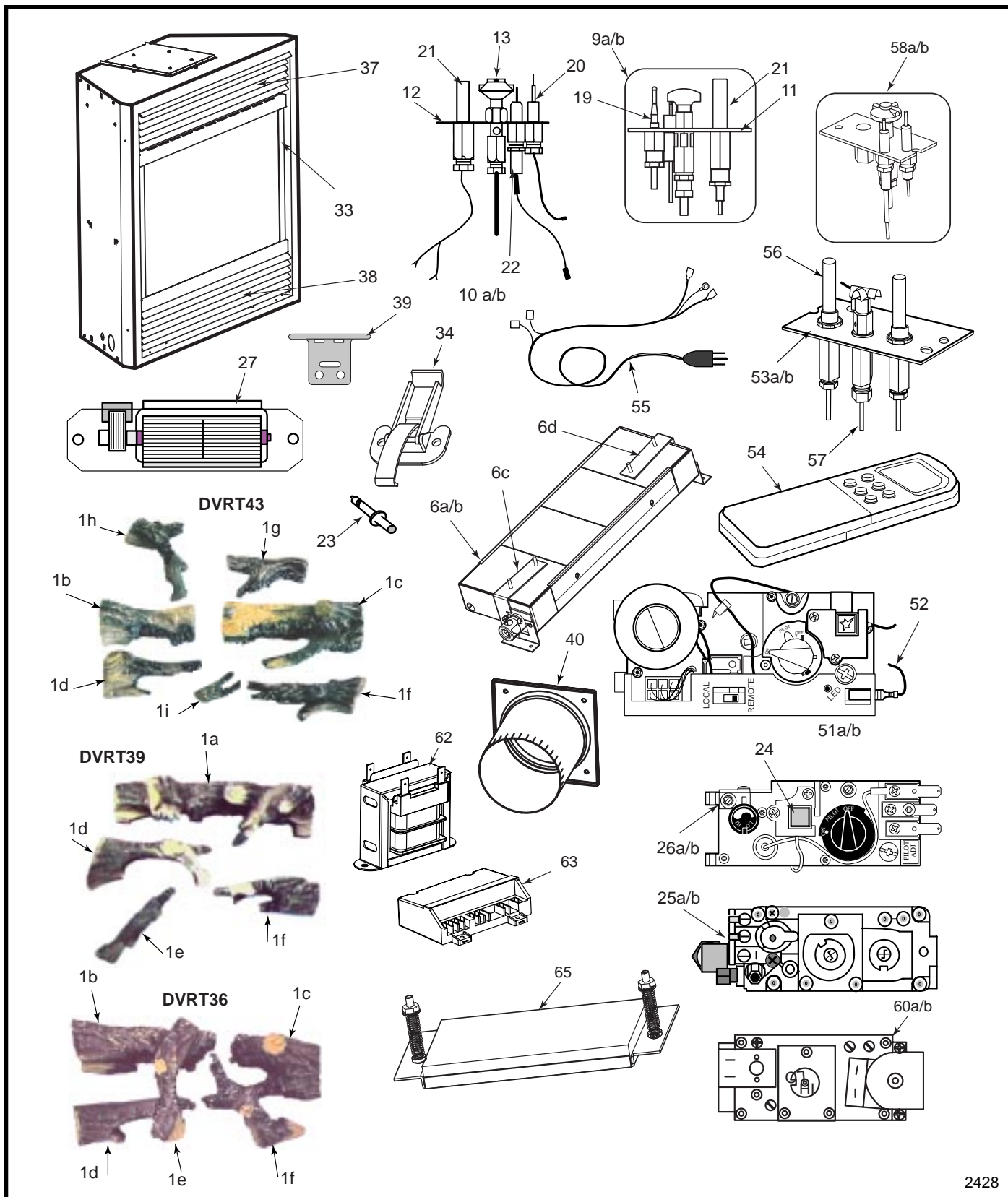

2428

Vermont Castings, Majestic Products reserves the right to make changes in design, materials, specifications and prices, and to discontinue colors and products at any time, without notice.

# DVRT36/39/43



**DVRT36/39/43 (continued)** (Items marked '\*\*' are not shown in the parts illustration.)

Ref.	Description	DVRT36	DVRT39	DVRT43
1.	Log Set (Complete)	10002427	10002469	10002853
1a.	Log - Rear	N/A	B35	N/A
1b.	Log - Rear Left	B43	N/A	B45
1c.	Log - Rear Right	B31	N/A	B46
1d.	Log - Front Left	B32	B37	N/A
1e.	Log - Top Left	B33	B38	N/A
1f.	Log - Front Right	B34	B36	B39
1g.	Log - Top Rear	N/A	N/A	B47
1h.	Log - Crossover Front Left	N/A	N/A	B50
1i.	Log - Front Center	N/A	N/A	B51
2.	Lava Rock - Burner (not shown)	57897	57897	57897
3.	Lava Rock (not shown)	10001454	10001454	10001454
4.	Rear Log Support Assembly (not shown)	10002425	10002471	10002855
5.	Front Grate Assembly (not shown)	10002432	10002432	10002852
6a.	Burner Housing Assembly - Natural	10002510	10002578	10002866
6b.	Burner Housing Assembly - LP	10002510	10002578	10002885
6c.	Log Support w/Stud Assembly	10002912	10002912	10002912
6d.	Log Support w/Stud Assembly	N/A	10002912	N/A
7.	Ceramic Tile (Single) (not shown)	57803	57803	57803
8a.	Orifice(s) - Main Burner - RN (not shown)	Refer to rating plate for orifice specifications		
8b.	Orifice(s) - Main Burner - RP (not shown)	Refer to rating plate for orifice specifications		
9a.	Pilot Assembly - PSE -Natural (3 Way)	10001741	10001741	10001741
9b.	Pilot Assembly - PSE - LP (3Way)	10001742	10001742	10001742
10a.	Pilot Assembly - SIT Top Conv. - Natural (3 Way)	10002264	10002264	10002264
10b.	Pilot Assembly - SIT Top Conv. - LP (3 Way)	10002265	10002265	10002265
11.	Pilot - PSE (with cable and electrode) (3 Way)	10001824	10001824	10001824
12.	Pilot - SIT Top Convertible	10002266	10002266	10002266
13.	Pilot Hood - SIT Top Convertible	10002385	10002385	10002385
14a.	Orifice - PSE Pilot - Natural (not shown)	10001822	10001822	10001822
14b.	Orifice - PSE Pilot - LP (not shown)	10001823	10001823	10001823
14c.	Orifice - SIT Top Conv. - Natural (not shown)	10002268	10002268	10002268
14d.	Orifice - SIT Top Conv. - LP (not shown)	10002269	10002269	10002269
15.	Pilot Tube w/Fittings - PSE (not shown)	53211	53211	53211
16.	Pilot Tube w/Fittings - SIT Top Conv. (not shown)	10001296	10001296	10001296
17.	Manifold Tube w/Fittings (not shown)	57318	57318	57318
18.	Flexible Gas Line (18") w/Fittings (not shown)	20002500	20002500	20002500
19.	Thermocouple - PSE	10001825	10001825	10001825
20.	Thermocouple - SIT Top Conv.	53373	53373	53373
21.	Thermopile	51827	51827	51827
22.	Ignitor Electrode w/Cable - SIT	10001297	10001297	10001297
23.	Ignitor Piezo - SIT 820 Gas Valve	52464	52464	52464
24.	Ignitor Piezo - Honeywell Gas Valve	20000062	20000062	20000062
25a.	Gas Valve - SIT 820 - Natural	52677	52677	52677
25b.	Gas Valve - SIT 820 - LP	52678	52678	52678
26a.	Gas Valve - Honeywell - Natural	10001782	10001782	10001782
26b.	Gas Valve - Honeywell - LP	10001759	10001759	10001759

**DVRT36/39/43 (continued)**

Ref.	Description	DVRT36	DVRT39	DVRT43
27.	FK24 Fan Assembly w/Bracket (Optional)	54103	54103	54103
28.	FK12 Fan Assembly (not shown)	ZA1110	ZA1110	ZA1110
29.	Electric Cord 6' (Optional) (not shown)	51865	51865	51865
30.	Fan Speed Control (Optional) (not shown)	51738	51738	51738
31.	Fan Speed Control Knob (Optional) (not shown)	51882	51882	51882
32.	Fan Temperature Sensor (Optional) (not shown)	51704	51704	51704
33.	Window Frame Assembly	10001425	10002478	10001805
34.	Lower Window Frame Clamps	54174	54174	54174
35.	Glass w/Gasket (not shown)	54427	54445	54564
36.	Window Glass Gasket (not shown)	57317	57317	57317
37.	Louvre Assembly Top	10000037	10000039	10000041
38.	Louvre Assembly Bottom	10000038	10000040	10000042
39.	Hinge - Bottom Louvre Assembly	52356	52356	52356
40.	Plate, Flue Pipe w/4' Pipe Assembly	10002509	10002509	10002509
41.	Plate, Flue Cover (not shown)	10002298	10002298	10002298
42.	Plate, Air Inlet Cover w/7" Collar (not shown)	10002766	10002766	10002766
43.	Gasket, Flue Cover Plate (not shown)	10002233	10002233	10002233
44.	Gasket, Flue Pipe Cover Plate (not shown)	10002237	10002237	10002237
45.	Gasket, Air Inlet Pipe (not shown)	10002449	10002449	10002449
46.	Remote ON/OFF Switch (not shown)	51842	51842	51842
47.	Wire Harness - Remote Switch (not shown)	55923	55923	55923
48.	Remote ON/OFF Switch Kit (Incls. above w/brckt)(not shown)	53875	53875	53875
49.	EB-1 Electrical/Connection Box Kit (Optional) (not shown)	ZA1200	ZA1200	ZA1200
50.	Ceramic Lining Kit (Optional) (not shown)	BT2TBO	CT2TBO	N/A
50a.	Ceramic Lining Kit Standard on DVRT43 (not shown)	N/A	N/A	10000459
51a.	RF Valve - Natural	20003719	20003719	20003719
51b.	RF Valve - LP	20003720	20003720	20003720
52.	Antennae	20003561	20003561	20003561
53a.	Pilot - RF - Natural (3 Way)	20002266	20002266	20002266
53b.	Pilot - RF - LP (3 Way)	20002268	20002268	20002268
54.	Transmitter	20002047	20002047	20002047
55.	Cord Set	20002541	20002541	20002541
56.	Thermopile	20002400	20002400	20002400
57.	Pilot Tube 1/8" x 24" Long w/ Fittings (PSE Pilot)	10003279	10003279	10003279
58a.	Pilot Assembly, SIT Top Convertible EN	10002387	10002387	10002387
58b.	Pilot Assembly, SIT Top Convertible EP	10002388	10002388	10002388
59.	Cable Igniter, EN & EP (not shown)	10000696	10000696	10000696
60a.	Gas Valve, SIT 822 EN	57884	57884	57884
60b.	Gas Valve, SIT 822 EP	57883	57883	57883
61.	Sensing Electrode (with Cable) EN & EP (not shown)	57885	57885	57885
62.	Transformer, EN & EP	7522409	7522409	7522409
63.	Ignition Module, Honeywell, EN & EP	20000005	20000005	20000005
64.	Wire Harness, Honeywell, EN & EP (not shown)	10001979	10001979	10001979
65.	Relief Plate with Gasket Assy Burner Tray	10004192	10004192	10004192
66.	Ignition Syntek EN & EP (not shown)	57899	57899	57899
67.	Wiring Harness, Syntek EN & EP (not shown)	10000417	10000417	10000417

## Optional Accessories

### Fan Kits

#### FK-12 Fan Assembly

1. Open lower louvre.
2. Install FK-12 fan in back of unit between hearth supports. (Fig. 57)
3. Secure fan on Velcro strips.
4. Power to the fan can be supplied by plugging the supply lead into a conveniently located wall socket or by using a hard-wired EB-1 connector box.
5. Be sure fan motor does not touch nearby metal.

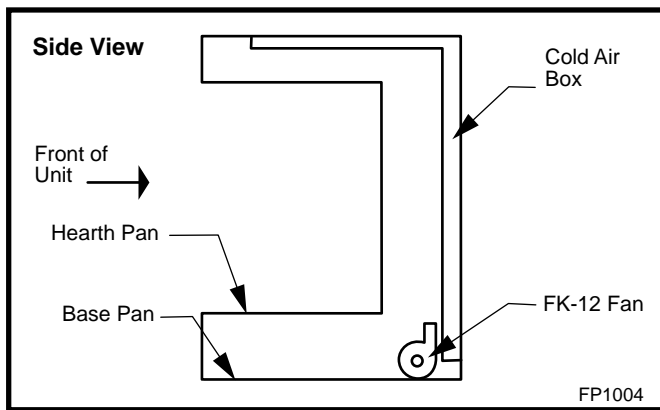

Fig. 57 FK-12 Fan Kit placement.

#### FK-24 Fan Assembly

Fan specifications: 120 Volt, 60 Hz 75 Amp.

This fan does not require regular maintenance, however periodic cleaning is required. Check the area under the control door and in front of the fan and wipe or vacuum at least once a month during the operating season.

Should this fan require servicing, the power supply must be disconnected.

The FK-24 comes with the electrical cord attached.

1. Slide fan assembly from the left side into the fireplace opening, line up mounting holes with screw studs on back of fireplace and fasten with #10-24 hex nuts.
2. Install thermal sensor on bottom of firebox using #10-24 hex nuts.
3. **Option A:** Place electronic fan speed control box on bottom of fireplace base, lining up mounting holes with screw studs. Fasten fan speed control box with #10-24 hex nuts.

**Option B:** The speed control can be installed in an electrical box at normal wall switch height for convenient access.

4. The power supply may be connected in 2 ways:

**Method A:** Route the 6' (1.8m) lead fitted to the unit to a conveniently located wall socket.

**Method B:** If the EB-1 receptacle box (Part # ZA1200) was correctly connected when the unit was installed, the fan lead can be directly plugged into the EB-1 plug socket.

5. Whether wiring directly to the fan junction box (Option A) or into the EB-1 (electrical receptacle box, Option B), first ensure cable is secured using box connector.



**The fireplace when installed, must be electrically connected and grounded in accordance with local codes or, in the absence of local codes, with the current CSA C22.1 Canadian Electrical Code. For USA installations, follow local codes and the National Electrical Code, ANSI/NFPA No. 70.**

### Hard (Direct) Wire Hookup

First connect ground wire to ground stud located on the base of either box. Black wire from supply should connect to the variable speed switch. Alternate speed switch wire connects to temperature sensor. Alternate lead from sensor connects to fan. Alternate fan lead connects back to the white supply wire. (Fig. 59)



**Any electrical rewiring of this fan must be completed by a qualified electrician.**

**Turn off all power before hookup.**

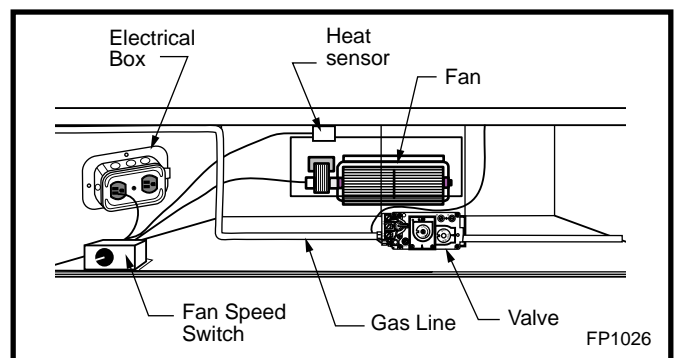

Fig. 58 FK-24 fan placement.

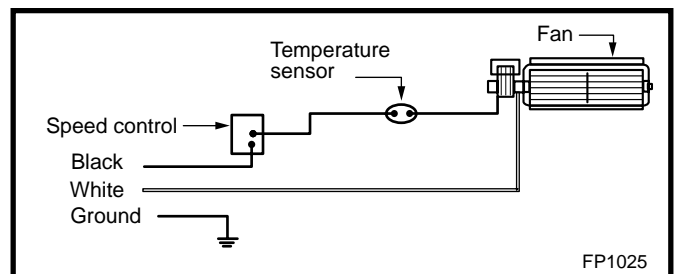

Fig. 59 FK-24 fan wiring.

## Remote Controls

Optional remote control units are available to control different functions of the appliance.

Model	Function(s) Controlled
MRC1	On/Off
MRC2	On/Off and Temperature
MRC3	On/Off and Temperature control with digital display and programmable 24-hour clock
IMT	Wall-mounted Thermostat Control

## Ceramic Refractory Panels

Ceramic refractory panels are available to line the firebox area. The ceramic lining kit for the DVRT43 is supplied standard with the appliance.

Unit	Kit Model
DVRT36	CR KIT DVT36
DVRT39	CR KIT DVT39

For installation, refer to Figures 59 and 60.



**Take care when handling the refractory panels, as they are fragile until secured in place and supported.**

1. Remove the window frame assembly.
2. Remove the logs.
3. Place the lower supports for the side refractory panels on the base of the firebox. Place each support so that the slotted hole fits over the forward screw head along the edge of the base.
4. Lay the angular base panels in place on the floor of the firebox on either side of the burner housing assembly.
5. Loosely attach the top adjustable tabs to the studs located in the top of the firebox toward the front corners.
6. Place the rear refractory panel in place. Locate the 'small brick' edge of the panel into the two small supports on the back panel just above the rear log support.
7. Slide the side refractory panels into place to hold the rear panel secure. Adjust the top adjustable tabs to hold the side panel against the firebox wall and secure the tab. Repeat the procedure on the other side.
8. Replace the logs and window frame assembly.

**NOTE: For aesthetic purposes, aligning the horizontal mortar lines is recommended.**

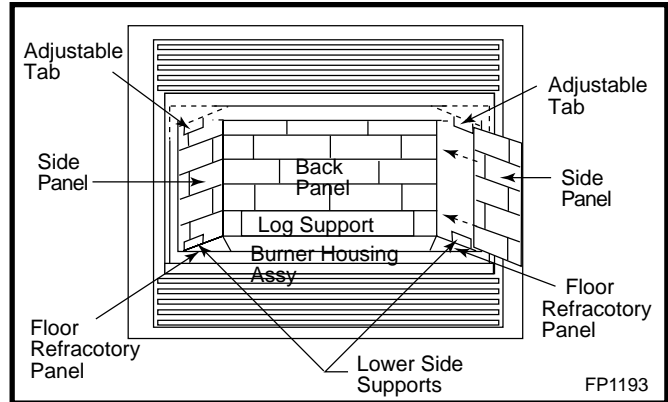

Fig. 60 Install ceramic refractory panels.

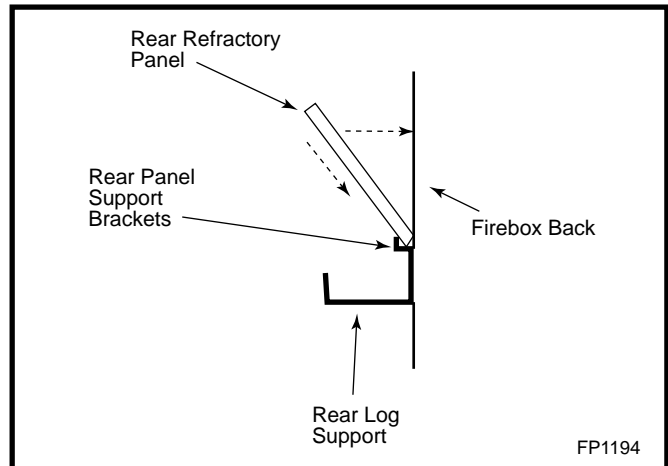

Fig. 61 Place the rear panel on rear support brackets.

## Decorative Bay Window



**When fitting the bay window kits the original front frame/glass assembly must remain in place. The bay window kit is fitted over the existing front glass.**

Bay window kits are available for the DVRT36 and DVRT39 model fireplaces.

### Installation

1. Remove the existing louvre assembly bottom complete with the hinges.
2. Remove the louvre assembly top.
3. Assemble the bay window kit according to the instructions supplied with the kit.
4. Place the two pieces of ceramic refractory along the base of the bay window. (Fig. 62)
5. Hang the bay window assembly over the existing window frame assembly.
6. Reinstall the upper louvre assembly.



**Do not remove the existing window frame assembly.**

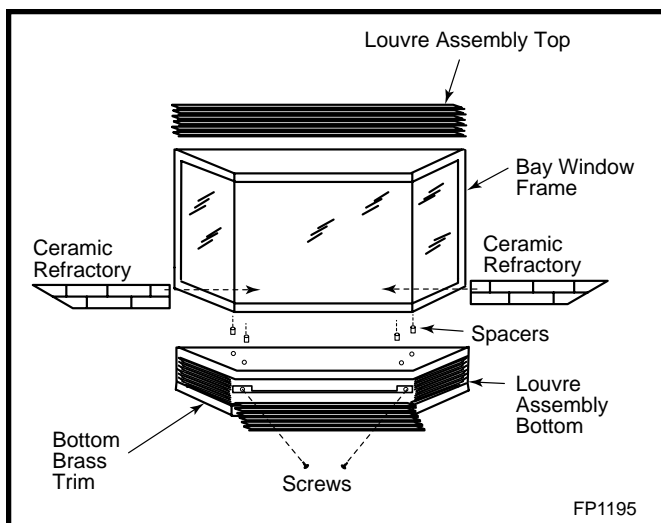

Fig. 62 Bay window.

### Decorative Frame Trim

A selection of decorative frame trim kits is available for mounting around the outside of the appliance to enhance its visual affect on the room. Installation instructions for each decorative frame trim are included with the frame trim kit. Contact your authorized distributor for details of the trim kits and ordering information for the trim kits applicable to this model appliance.

## For Use in Mobile Homes: Model DVRT36RMH

**This appliance may be installed as an OEM installation in a manufactured home (US only), or a mobile home; it must be installed in accordance with the manufacturer's instructions and the manufactured home construction and safety standard Title 24 CFR Part 3280, or Standard for Installation in Mobile Homes CAN/ CSA Z240 MH.**

**This appliance is only for use with the type(s) of gas indicated on the rating plate. A conversion kit is supplied with the appliance.**

This gas fireplace should be installed by a qualified installer in accordance with local building codes, and with current CSA-B149.1 Installation codes for Gas Burning Fireplaces and Equipment, and CAN/ CSA Z 240.4 Canada.

A manufactured home (US only) or mobile home OEM installation must conform with the Manufactured Home Construction and Safety Standard, Title 24 CFR Part 3280, or when such a standard is not applicable, the Standard for Manufactured Home Installations ANSI/NCSBCS A225.1, or Standard for Gas Equipped Recreational Vehicles and Mobile Housing CSA Z240.4.

The appliance when installed, must be electrically grounded in accordance with local codes or, in the absence of local codes, with the current National Electrical Code, ANSI/NFPA 70, or the Canadian Electrical Code, CSA C22.1.

### **FOR SAFE INSTALLATION AND OPERATION PLEASE NOTE THE FOLLOWING:**

1. This fireplace gives off high temperatures and should be located out of high traffic areas and away from furniture and draperies.
2. Children and adults should be alerted to the hazards of fireplace high surface temperatures and should stay away to avoid burns or ignition of clothing.
3. Children should be carefully supervised when in the same room as your fireplace.
4. Under no circumstances should this fireplace be modified. Parts removed for servicing should be replaced prior to operating this fireplace again.
5. Installation and any repairs to fireplace should be performed by qualified installer, service agency or gas supplier. A professional service person should be contacted to inspect fireplace annually. More frequent cleaning may be required due to excess lint and dust from carpeting, bedding material, etc.
6. Control compartments, burners and air passages in this fireplace should be kept clean and free of dust and lint. Make sure that the gas valve and pilot light are turned off before you attempt to clean this fireplace.
7. The venting system (chimney) of this fireplace

should be checked at least once a year and if needed your venting system should be cleaned.

8. Keep the area around your fireplace clear of combustible materials, gasoline and other flammable vapor and liquids. This fireplace should not be used as a drying rack for clothing, nor should Christmas stockings or decorations be hung on or around the fireplace.
9. Under no circumstances should any solid fuels (wood, coal, paper or cardboard etc.) be used in this fireplace.
10. The flow of combustion and ventilation air must not be obstructed in any way.
11. When the fireplace is installed directly on carpeting, vinyl tile or any combustible material other than wood, the fireplace must be installed on a metal or wood panel extending the full width and depth of the fireplace.
12. This fireplace requires adequate ventilation and combustion air to operate properly.



**Vermont Castings, Majestic Products Model DVRT36RMH must be firmly attached to the building.**

### **Conversion Instructions**

1. Disconnect power to unit and shut off the gas supply.
2. Remove the window frame assembly (see 'Window Frame Assembly' section).
3. Carefully remove the logs.
4. Remove the pilot assembly from bracket.
5. Remove the screws which are holding the burner housing assembly in place.
6. Remove the burner housing assembly.
7. Remove the main and front orifice and replace with the orifice supplied in the conversion kit. Use the small orifice size for the front burner and the bigger orifice size for the main burner.

8. Remove the compression fitting which holds the aluminium tubing in the pilot assembly. This will reveal the pilot orifice which must be replaced with the one provided in the conversion kit.

9a. **Units with SIT valve** (see pictures in the installation instructions supplied with the kit):

- a) Using a Torx T20 or slotted screwdriver, remove and save the three pressure regulator mounting screws (A), pressure regulator tower (B) and diaphragm (C).
- b) Ensure the rubber gasket (D) is properly positioned and install the new Hi/ Lo pressure regulator to the valve using the new screws (E) supplied with the kit. Tighten screws securely. (Ref. torque: 25 in-lb).
- c) Install the enclosed identification label (F) to the valve body where it can be easily seen.

9b. **Units with Honeywell valve:**

The Honeywell valve fitted to this unit is preset for LP gas. It is convertible to natural gas by the installation of a color coded "conversion screw." To insert the conversion screw, refer to the instructions and diagrams in the Honeywell Installation Instructions supplied in the conversion kit packaged with the DVRT36RMH unit.

10. Reassemble the fireplace in the reverse order, except for the window frame assembly. Leave this off until the unit has been checked for leaks and the gas supply line has been bled.

11. After bleeding the gas line and checking for leaks with a soap solution, replace the window frame assembly. Fire up the unit, check for flame impingement on the logs, adjusting them if necessary. Check the manifold and supply pressures.

**NOTE: If further assistance is required, refer to 'Troubleshooting' and 'Parts List' in this manual.**

# LIMITED LIFETIME WARRANTY

## PRODUCT COVERED BY THIS WARRANTY

All Vermont Castings gas stoves, gas inserts, and gas fireplaces, and all Majestic or Northern Flame brand gas fireplaces equipped with an Insta-Flame Ceramic Burner, or standard steel tube burner.

### BASIC WARRANTY

Vermont Castings, Majestic Products (hereinafter referred to collectively as the Company) warrants that your new Vermont Castings or Majestic Gas Fireplace/Stove is free from manufacturing and material defects for a period of one year from the date of purchase, subject to the following conditions and limitations.

### EXTENDED LIFETIME WARRANTY

The heat exchanger, where applicable, and combustion chamber of every Vermont Castings or Majestic gas product is warranted for life against through wall perforation. All appliances equipped with an Insta-Flame Ceramic Burner have limited lifetime coverage on the ceramic burner plaque. Warrantees are made to the original owner subject to proof of purchase and the conditions and limitations listed on this Warranty Document

### COMPONENT WARRANTY

**CAST IRON:** All external and internal cast iron parts are warranted for a period of three years.

**Note:** On porcelain enamel finished external parts and accessories The Company offers no Warranty on chipping of enamel surfaces. Inspect all product prior to accepting it for any damage to the enamel.

The salt air environment of coastal areas or a high humidity environment can be corrosive to the porcelain enamel finish. These conditions can cause rusting of the cast iron beneath the porcelain enamel finish, which will cause the finish to flake off.

Dye lot variations with replacement parts and/or accessories can occur and are not covered by warranty.

**GLASS DOORS:** Glass doors are covered for a period of one year.

Glass doors are not warranted for breakage due to misuse or accident. Glass doors are not covered for discoloration or burned in stains due to environmental issues, or improper cleaning and maintenance.

**BRASS PLATED PARTS AND ACCESSORIES:** Brass parts should be cleaned with Lemon oil only. Brass cleaners cannot be used. Mortar mix and masonry cleaners may corrode the brass finish. The Company will not be responsible for, nor will it warrant any brass parts which are damaged by external chemicals or down draft conditions.

**GAS VALVES:** Gas valves are covered for a period of one year

**ELECTRONIC AND MECHANICAL COMPONENTS:** Electronic and mechanical components of the burner assembly are covered for one year. All steel tube burners are warranted for one year.

**ACCESSORIES:** Unless otherwise noted all components and Vermont Castings, Majestic Products company supplied accessories are covered for a period of one year.

### CONDITIONS AND LIMITATIONS

- This new Vermont Castings or Majestic product must be installed by a competent, authorized, service contractor. A licensed technician, as prescribed by the local jurisdiction must perform any installation/service work. It must be installed and operated at all times in accordance with the Installation and Operating instructions furnished with the product. Any alteration, willful abuse, accident, or misuse of the product shall nullify this warranty.
- This warranty is non-transferable, and is made to the original owner, provided that the purchase was made through an authorized supplier of the Company.
- The customer must pay for any Authorized Dealer in-home travel fees or service charges for in-home repair work. It is the dealers option whether the repair work will be done in the customer's home or in the dealer's shop.
- If upon inspection, the damage is found to be the fault of the manufacturer, repairs will be authorized at no charge to the customer parts and/or labor.

- Any part and/or component replaced under the provisions of this warranty is covered for six months or the remainder of the original warranty, whichever is longest.
- This warranty is limited to the repair of or replacement of part(s) found to be defective in material or workmanship, provided that such part(s) have been subjected to normal conditions of use and service, after said defect is confirmed by the Company's inspection.
- The company may, at its discretion, fully discharge all obligations with respect to this warranty by refunding the wholesale price of the defective part(s)
- Any installation, labor, construction, transportation, or other related costs/expenses arising from defective part(s), repair, replacement, or otherwise of same, will not be covered by this warranty, nor shall the Company assume responsibility for same. Further, the Company will not be responsible for any incidental, indirect, or consequential damages except as provided by law.
- *SOME STATES DO NOT ALLOW FOR THE EXCLUSION OR LIMITATIONS OF INCIDENTAL AND CONSEQUENTIAL DAMAGES OR LIMITATIONS ON HOW LONG AN IMPLIED WARRANTY LASTS, SO THE ABOVE LIMITATIONS MAY NOT APPLY TO YOUR CIRCUMSTANCES. THIS WARRANTY GIVES YOU SPECIFIC RIGHTS AND YOU MAY HAVE OTHER RIGHTS WHICH VARY FROM STATE TO STATE.*
- All other warranties-expressed or implied- with respect to the product, its components and accessories, or any obligations/liabilities on the part of the Company are hereby expressly excluded.
- The Company neither assumes, nor authorizes any third party to assume on its behalf, any other liabilities with respect to the sale of this Vermont Castings, Majestic product
- The warranties as outlined within this document do not apply to chimney components or other non Vermont Castings, Majestic accessories used in conjunction with the installation of this product..
- Damage to the unit while in transit is not covered by this warranty but is subject to claim against the common carrier. Contact the dealer from whom you purchased your fireplace/stove (do not operate the appliance as this might negate the ability to process the claim with the carrier).
- The Company will not be responsible for:
  - a) Down drafts or spillage caused by environmental conditions such as near-by trees, buildings, roof tops, hills, or mountains.
  - b) Inadequate ventilation or negative air pressure caused by mechanical systems such as furnaces, fans, clothes dryers, etc.
- This warranty is void if:
  - a) The fireplace has been operated in atmospheres contaminated by chlorine, fluorine, or other damaging chemicals.
  - b) The fireplace has been subjected to prolonged periods of dampness or condensation
  - c) Any damages to the fireplace, combustion chamber, heat exchanger or other components due to water, or weather damage, which is the result of but not limited to, improper chimney/venting installation.
  - d) Any alteration, willful abuse, accident, or misuse of the product has occurred.

### IF WARRANTY SERVICE IS NEEDED...

- 1) Contact your supplier. Make sure you have your warranty, your sales receipt, and the model/serial number of your Vermont Castings, Majestic product.
- 2) DO NOT ATTEMPT TO DO ANY SERVICE WORK YOURSELF.





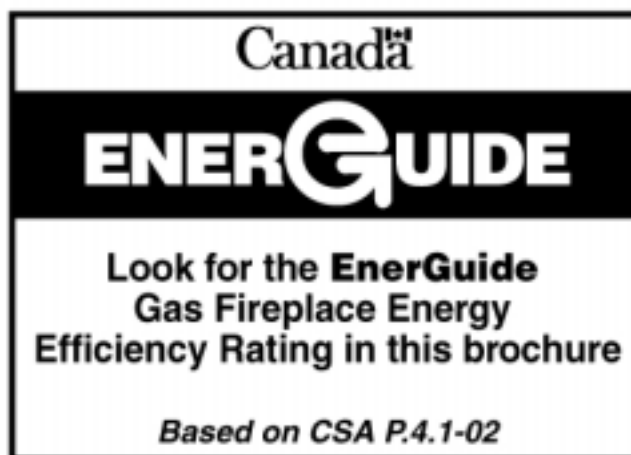

Efficiency Ratings				
Model	EnerGuide Ratings Fireplace Efficiency (%)	Steady State (%)		D.O.E. (AFUE%)
		Fan-OFF	Fan-ON	
DVRT36RN	59.5	83	84	63
DVRT36EN	59.8	84	85	63
DVRT36EN	59.5	83	84	63
DVRT36EP	59.8	84	85	63
DVRT36RFN	59.5	83	84	63
DVRT36RFP	59.8	84	85	63
DVRT36RMH	59.5	83	84	63
DVRT39RN	65.4	83	84	64
DVRT39RP	66.8	84	85	64
DVRT39EN	65.4	83	84	64
DVRT39EP	66.8	84	85	64
DVRT43RN	63.7	83	84	64
DVRT43RP	63.7	84	85	64
DVRT43EN	63.7	83	84	64
DVRT43EP	63.7	84	85	64

**Vermont Castings, Majestic Products**

410 Admiral Blvd. • Mississauga, Ontario, Canada L5T 2N6 • 905-670-7777  
 www.majesticproducts.com • www.vermontcastings.com